

5 - 85 MHz 24-bit Color FPD-Link III Serializer with Bidirectional Control Channel

General Description

The DS90UB925Q serializer, in conjunction with the DS90UB926Q deserializer, provides a complete digital interface for concurrent transmission of high-speed video, audio, and control data for automotive display and image sensing applications.

The chipset is ideally suited for automotive video-display systems with HD formats and automotive vision systems with megapixel resolutions. The DS90UB925Q incorporates an embedded bidirectional control channel and low latency GPIO controls. This chipset translates a parallel interface into a single pair high-speed serialized interface. The serial bus scheme, FPD-Link III, supports full duplex of high-speed video data transmission and bidirectional control communication over a single differential link. Consolidation of video data and control over a single differential pair reduces the interconnect size and weight, while also eliminating skew issues and simplifying system design.

The DS90UB925Q serializer embeds the clock, DC scrambles & balances the data payload, and level shifts the signals to high-speed low voltage differential signaling. Up to 24 data bits are serialized along the video control signals.

Serial transmission is optimized by a user selectable de-emphasis. EMI is minimized by the use of low voltage differential signaling, data scrambling and randomization and spread spectrum clocking compatibility.

Features

- Bidirectional control interface channel interface with I2C compatible serial control bus
- Supports high definition (720p) digital video format
- RGB888 + VS, HS, DE and I2S audio supported
- Supports two 10-bit camera video streams
- 5 – 85MHz PCLK supported
- Single 3.3V Operation with 1.8V or 3.3V compatible LVCMOS I/O interface
- AC-coupled STP Interconnect up to 10 meters
- Parallel LVCMOS video inputs
- DC-balanced & scrambled Data w/ Embedded Clock
- Supports repeater application
- Internal pattern generation
- Low power modes minimize power dissipation
- Automotive grade product: AEC-Q100 Grade 2 qualified
- >8kV HBM and ISO 10605 ESD rating
- Backward compatible to FPD-Link II

Applications

- Automotive Display for Navigation
- Rear Seat Entertainment Systems
- Automotive Driver Assistance
- Automotive Megapixel Camera Systems

Typical Display Applications Diagram

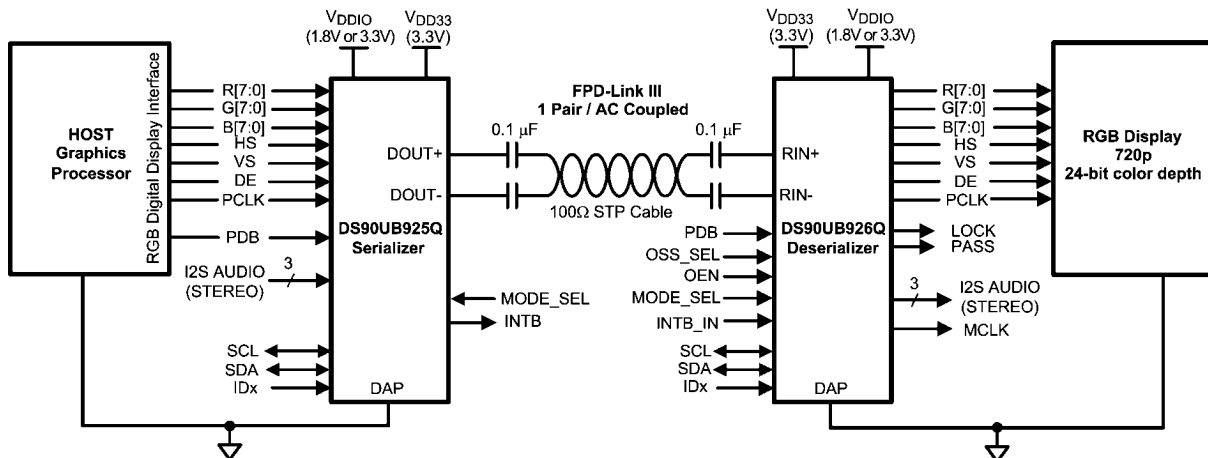

30143327

Typical Camera Applications Diagram

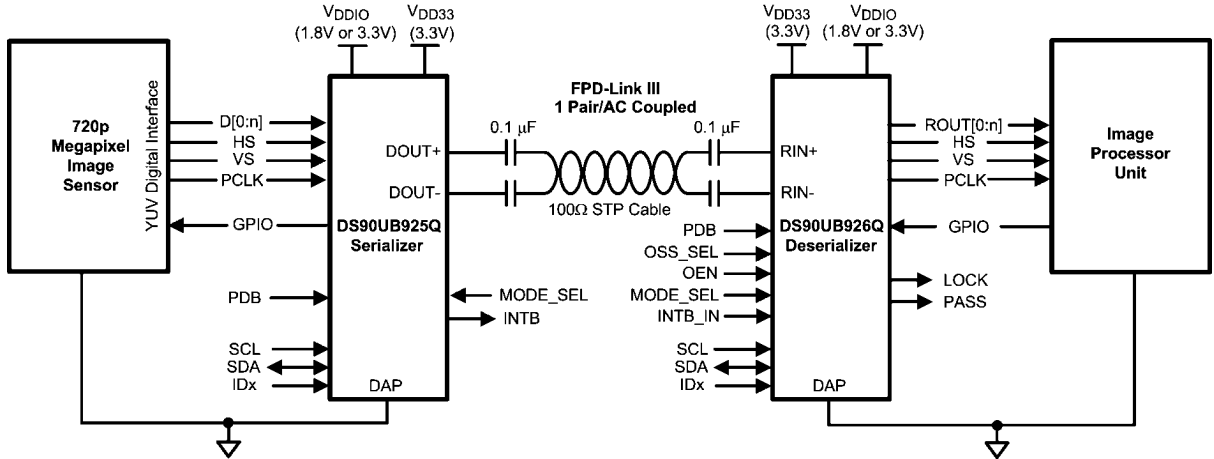

30143326

DS90UB925Q Pin Diagram

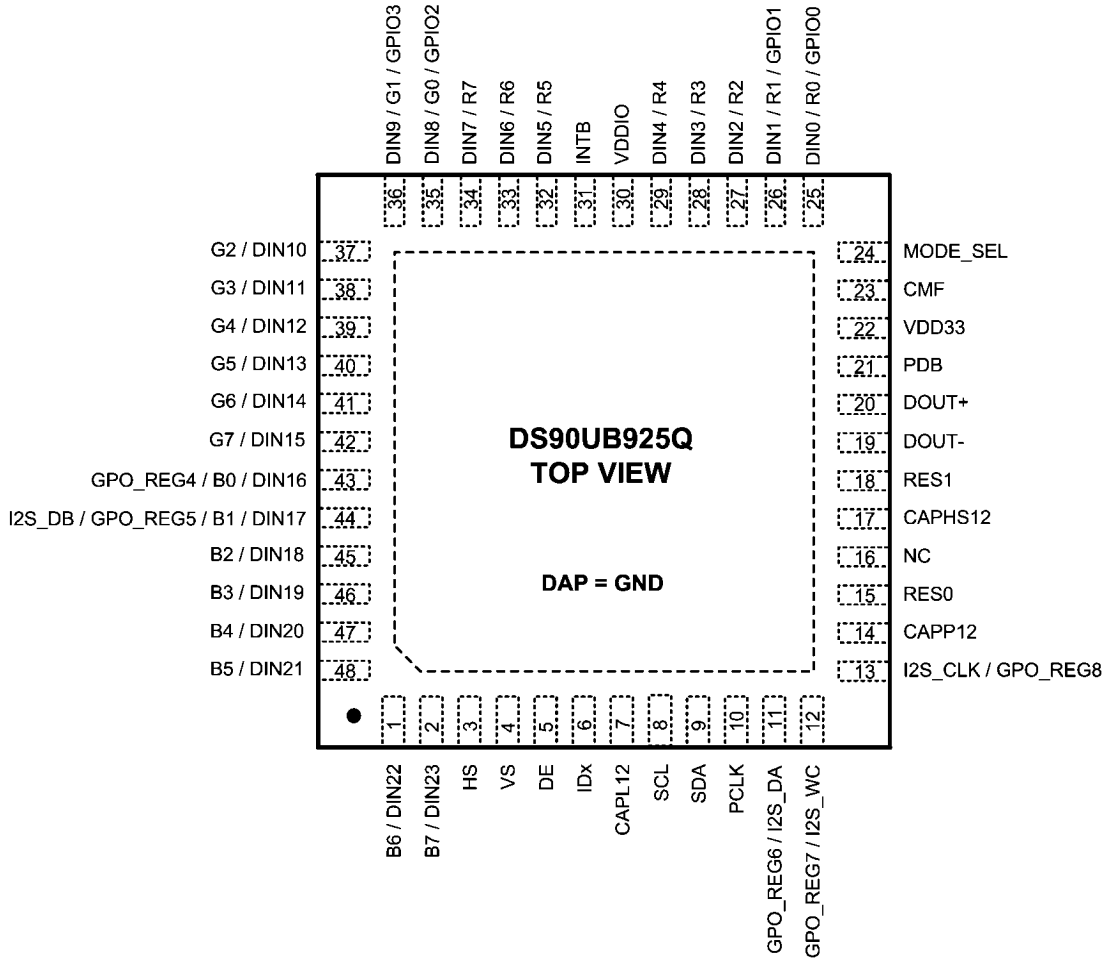

DS90UB925Q — Top View

30143319

Pin Descriptions

| Pin Name | Pin # | I/O, Type | Description |
|---|---|---------------------------------|--|
| LVC MOS Parallel Interface | | | |
| DIN[23:0] / R [7:0], G[7:0], B[7:0] | 25, 26, 27, 28, 29, 32, 33, 34, 35, 36, 37, 38, 39, 40, 41, 42, 43, 44, 45, 46, 47, 48, 1, 2 | I, LVC MOS w/ pull down | Parallel Interface Data Input Pins Leave open if unused DIN0 / R0 can optionally be used as GPIO0 and DIN1 / R1 can optionally be used as GPIO1 DIN8 / G0 can optionally be used as GPIO2 and DIN9 / G1 can optionally be used as GPIO3 DIN16 / B0 can optionally be used as GPIO4 and DIN17 / B1 can optionally be used as GPIO5 |
| HS | 3 | I, LVC MOS w/ pull down | Horizontal Sync Input Pin Video control signal pulse width must be 3 PCLKs or longer to be transmitted when the Control Signal Filter is enabled. There is no restriction on the minimum transition pulse when the Control Signal Filter is disabled. The signal is limited to 2 transitions per 130 PCLKs. See Table 6 |
| VS | 4 | I, LVC MOS w/ pull down | Vertical Sync Input Pin Video control signal is limited to 1 transition per 130 PCLKs. Thus, the minimum pulse width is 130 PCLKs. |
| DE | 5 | I, LVC MOS w/ pull down | Data Enable Input Pin Video control signal pulse width must be 3 PCLKs or longer to be transmitted when the Control Signal Filter is enabled. There is no restriction on the minimum transition pulse when the Control Signal Filter is disabled. The signal is limited to 2 transitions per 130 PCLKs. See Table 6 |
| PCLK | 10 | I, LVC MOS w/ pull down | Pixel Clock Input Pin. Strobe edge set by RFB configuration register. See Table 6 |
| I2S_CLK, I2S_WC, I2S_DA | 13, 12, 11 | I, LVC MOS w/ pull down | Digital Audio Interface Data Input Pins Leave open if unused I2S_CLK can optionally be used as GPO_REG8, I2S_WC can optionally be used as GPO_REG7, and I2S_DA can optionally be used as GPO_REG6. |
| Optional Parallel Interface | | | |
| I2S_DB | 44 | I, LVC MOS w/ pull down | Second Channel Digital Audio Interface Data Input pin at 18-bit color mode and set by MODE_SEL pin or configuration register Leave open if unused I2S_DB can optionally be used as DIN17 or GPO_REG5. |
| GPIO[3:0] | 36, 35, 26, 25 | I/O, LVC MOS w/ pull down | General Purpose I/Os. Available only in 18-bit color mode, and set by MODE_SEL pin or configuration register. See Table 6 Leave open if unused Shared with DIN9, DIN8, DIN1 and DIN0 |
| GPO_REG [8:4] | 13, 12, 11, 44, 43 | O, LVC MOS w/ pull down | General Purpose Outputs and set by configuration register. See Table 6 Share with I2S_CLK, I2S_WC, I2S_DA, I2S_DB or DIN17, DIN16. |
| Control | | | |
| PDB | 21 | I, LVC MOS w/ pull-down | Power-down Mode Input Pin PDB = H, device is enabled (normal operation) Refer to "Power Up Requirements and PDB Pin" in the Applications Information Section. PDB = L, device is powered down. When the device is in the powered down state, the Driver Outputs are both HIGH, the PLL is shutdown, and IDD is minimized. Control Registers are RESET . |
| MODE_SEL | 24 | I, Analog | Device Configuration Select. See Table 1 |
| I2C | | | |
| IDx | 6 | I, Analog | I2C Serial Control Bus Device ID Address Select External pull-up to V _{DD33} is required under all conditions, DO NOT FLOAT. Connect to external pull-up and pull-down resistor to create a voltage divider. See Figure 17 |

| Pin Name | Pin # | I/O, Type | Description |
|--------------------------------------|--------|------------------------------|---|
| SCL | 8 | I/O, LVCMOS Open Drain | I2C Clock Input / Output Interface Must have an external pull-up to V_{DD33} , DO NOT FLOAT. Recommended pull-up: 4.7k Ω . |
| SDA | 9 | I/O, LVCMOS Open Drain | I2C Data Input / Output Interface Must have an external pull-up to V_{DD33} , DO NOT FLOAT. Recommended pull-up: 4.7k Ω . |
| Status | | | |
| INTB | 31 | O, LVCMOS Open Drain | Interrupt INTB = H, normal INTB = L, Interrupt request Recommended pull-up: 4.7k Ω to V_{DDIO} |
| FPD-Link III Serial Interface | | | |
| DOUT+ | 20 | O, LVDS | True Output The output must be AC-coupled with a 0.1 μ F capacitor. |
| DOUT- | 19 | O, LVDS | Inverting Output The output must be AC-coupled with a 0.1 μ F capacitor. |
| CMF | 23 | Analog | Common Mode Filter. Connect 0.1 μ F to GND |
| Power and Ground | | | |
| V_{DD33} | 22 | Power | Power to on-chip regulator 3.0 V - 3.6 V . Requires 4.7 uF to GND |
| V_{DDIO} | 30 | Power | LVCMOS I/O Power 1.8 V \pm5% OR 3.0 V - 3.6 V . Requires 4.7 uF to GND |
| GND | DAP | Ground | DAP is the large metal contact at the bottom side, located at the center of the LLP package. Connect to the ground plane (GND) with at least 9 vias. |
| Regulator Capacitor | | | |
| CAPHS12, CAPP12 | 17, 14 | CAP | Decoupling capacitor connection for on-chip regulator. Requires a 4.7uF to GND at each CAP pin. |
| CAPL12 | 7 | CAP | Decoupling capacitor connection for on-chip regulator. Requires two 4.7uF to GND at this CAP pin. |
| Others | | | |
| NC | 16 | NC | Do not connect. |
| RES[1:0] | 18, 15 | GND | Reserved. Tie to Ground. |

The VDD (V_{DD33} and V_{DDIO}) supply ramp should be faster than 1.5 ms with a monotonic rise.

Block Diagram

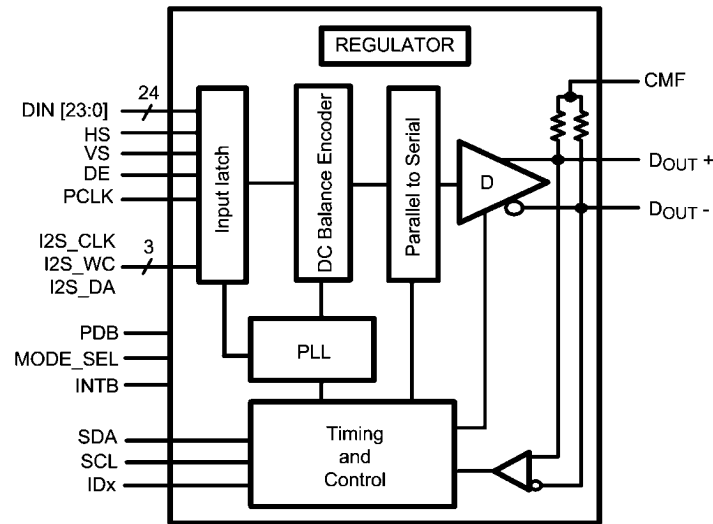

DS90UB925Q Serializer

30143328

Ordering Information

| PART NUMBER | PACKAGE DESCRIPTION | QUANTITY | SPEC | PACKAGE ID |
|---------------|--|----------|------|------------|
| DS90UB925QSQE | 48-pin LLP, 7.0 X 7.0 X 0.8 mm, 0.5 mm pitch | 250 | NOPB | SQA48A |
| DS90UB925QSQ | 48-pin LLP, 7.0 X 7.0 X 0.8 mm, 0.5 mm pitch | 1000 | NOPB | SQA48A |
| DS90UB925QSQX | 48-pin LLP, 7.0 X 7.0 X 0.8 mm, 0.5 mm pitch | 2500 | NOPB | SQA48A |

Note: Automotive Grade (Q) product incorporates enhanced manufacturing and support processes for the automotive market, including defect detection methodologies. Reliability qualification is compliant with the requirements and temperature grades defined in the AEC Q100 standard. Automotive Grade products are identified with the letter Q. For more information go to <http://www.ti.com/automotive>.

Absolute Maximum Ratings *(Note 1)*

If Military/Aerospace specified devices are required, please contact the Texas Instruments Sales Office/ Distributors for availability and specifications.

| | |
|---|--------------------------------|
| Supply Voltage – V_{DD33} | -0.3V to +4.0V |
| Supply Voltage – V_{DDIO} | -0.3V to +4.0V |
| LVC MOS I/O Voltage | -0.3V to ($V_{DDIO} + 0.3V$) |
| Serializer Output Voltage | -0.3V to +2.75V |
| Junction Temperature | +150°C |
| Storage Temperature | -65°C to +150°C |
| 48L LLP Package | |
| Maximum Power Dissipation Capacity at 25°C | |
| Derate above 25°C | $1/\theta_{JA}$ °C/W |
| θ_{JA} | 35 °C/W |
| θ_{JC} | 5.2 °C/W |
| ESD Rating (IEC, powered-up only), $R_D = 330\Omega$, $C_S = 150pF$ | |
| Air Discharge (D_{OUT+} , D_{OUT-}) | $\geq \pm 15$ kV |
| Contact Discharge (D_{OUT+} , D_{OUT-}) | $\geq \pm 8$ kV |
| ESD Rating (ISO10605), $R_D = 330\Omega$, $C_S = 150pF$ | |
| Air Discharge (D_{OUT+} , D_{OUT-}) | $\geq \pm 15$ kV |
| Contact Discharge (D_{OUT+} , D_{OUT-}) | $\geq \pm 8$ kV |
| ESD Rating (ISO10605), $R_D = 2k\Omega$, $C_S = 150pF$ or $330pF$ | |
| Air Discharge (D_{OUT+} , D_{OUT-}) | $\geq \pm 15$ kV |
| Contact Discharge (D_{OUT+} , D_{OUT-}) | $\geq \pm 8$ kV |
| ESD Rating (HBM) | $\geq \pm 8$ kV |
| ESD Rating (CDM) | $\geq \pm 1.25$ kV |
| ESD Rating (MM) | $\geq \pm 250$ V |
| For soldering specifications: see product folder at www.ti.com and www.ti.com/lit/an/snoa549c/snoa549c.pdf | |

Recommended Operating Conditions

| | Min | Nom | Max | Units |
|--|------|-----|------|-------------------|
| Supply Voltage (V_{DD33}) | 3.0 | 3.3 | 3.6 | V |
| LVC MOS Supply Voltage (V_{DDIO}) | 3.0 | 3.3 | 3.6 | V |
| OR | | | | |
| LVC MOS Supply Voltage (V_{DDIO}) | 1.71 | 1.8 | 1.89 | V |
| Operating Free Air Temperature (T_A) | -40 | +25 | +105 | °C |
| PCLK Frequency | 5 | | 85 | MHz |
| Supply Noise <i>(Note 7)</i> | | | 100 | mV _{P-P} |

DC Electrical Characteristics

Over recommended operating supply and temperature ranges unless otherwise specified. ([Note 2](#), [Note 3](#), [Note 4](#))

| Symbol | Parameter | Conditions | Pin/Freq. | Min | Typ | Max | Units | |
|--|--|--|--|---------------------------------|---------------------------------|-------------------|------------|----------|
| LVCMOS I/O DC SPECIFICATIONS | | | | | | | | |
| V_{IH} | High Level Input Voltage | $V_{DDIO} = 3.0$ to $3.6V$ | PDB | 2.0 | | V_{DDIO} | V | |
| V_{IL} | Low Level Input Voltage | $V_{DDIO} = 3.0$ to $3.6V$ | | GND | | 0.8 | V | |
| I_{IN} | Input Current | $V_{IN} = 0V$ or $V_{DDIO} = 3.0$ to $3.6V$ | | -10 | ± 1 | +10 | μA | |
| V_{IH} | High Level Input Voltage | $V_{DDIO} = 3.0$ to $3.6V$ | DIN[23:0], HS, VS, DE, PCLK, I2S_CLK, I2S_WC, I2S_DA, I2S_DB | 2.0 | | V_{DDIO} | V | |
| | | $V_{DDIO} = 1.71$ to $1.89V$ | | $0.65^* V_{DDIO}$ | | V_{DDIO} | V | |
| V_{IL} | Low Level Input Voltage | $V_{DDIO} = 3.0$ to $3.6V$ | | GND | | 0.8 | V | |
| | | $V_{DDIO} = 1.71$ to $1.89V$ | | GND | | $0.35^* V_{DDIO}$ | V | |
| I_{IN} | Input Current | $V_{IN} = 0V$ or V_{DDIO} | | $V_{DDIO} = 3.0$ to $3.6V$ | -10 | ± 1 | +10 | μA |
| | | | | $V_{DDIO} = 1.71$ to $1.89V$ | -10 | ± 1 | +10 | μA |
| V_{OH} | High Level Output Voltage | $I_{OH} = -4mA$ | GPIO[3:0], GPO_REG [8:4] | $V_{DDIO} = 3.0$ to $3.6V$ | 2.4 | | V_{DDIO} | V |
| | | | | $V_{DDIO} = 1.71$ to $1.89V$ | $V_{DDIO} - 0.45$ | | V_{DDIO} | V |
| V_{OL} | Low Level Output Voltage | $I_{OL} = +4mA$ | | $V_{DDIO} = 3.0$ to $3.6V$ | GND | | 0.4 | V |
| | | | | $V_{DDIO} = 1.71$ to $1.89V$ | GND | | 0.35 | V |
| I_{OS} | Output Short Circuit Current | $V_{OUT} = 0V$ | | | -50 | | mA | |
| I_{OZ} | TRI-STATE® Output Current | $V_{OUT} = 0V$ or V_{DDIO} , PDB = L, | | | -10 | | +10 | μA |
| FPD-LINK III CML DRIVER DC SPECIFICATIONS | | | | | | | | |
| V_{ODp-p} | Differential Output Voltage (DOUT+) – (DOUT-) | $R_L = 100\Omega$, Figure 1 | DOUT+, DOUT- | 1160 | 1250 | 1340 | mVp-p | |
| ΔV_{OD} | Output Voltage Unbalance | | | | 1 | 50 | mV | |
| V_{OS} | Offset Voltage – Single-ended | $R_L = 100\Omega$, Figure 1 | | | $2.5-0.25^* V_{ODp-p}$ (TYP) | | | V |
| ΔV_{OS} | Offset Voltage Unbalance Single-ended | | | | 1 | 50 | mV | |
| I_{OS} | Output Short Circuit Current | DOUT+/- = 0V, PDB = L or H | | | -38 | | mA | |
| R_T | Internal Termination Resistor - Single ended | | | | 40 | 52 | 62 | Ω |

| Symbol | Parameter | Conditions | Pin/Freq. | Min | Typ | Max | Units | |
|-----------------------|---|--|---------------------------|------------|-----|-----|-------|---------------|
| SUPPLY CURRENT | | | | | | | | |
| I_{DD1} | Supply Current (includes load current) $R_L = 100\Omega$, $f = 85\text{MHz}$ | Checker Board Pattern, <i>Figure 2</i> | $V_{DD33} = 3.6\text{V}$ | V_{DD33} | | 148 | 170 | mA |
| I_{DDIO1} | | | $V_{DDIO} = 3.6\text{V}$ | V_{DDIO} | | 90 | 180 | μA |
| | | | $V_{DDIO} = 1.89\text{V}$ | | | 1 | 1.6 | mA |
| I_{DDS1} | Supply Current Remote Auto Power Down Mode | 0x01[7] = 1, deserializer is powered down | $V_{DD33} = 3.6\text{V}$ | V_{DD33} | | 1.2 | 2.4 | mA |
| | | | $V_{DDIO} = 3.6\text{V}$ | | | 65 | 150 | μA |
| I_{DDIOS1} | | | $V_{DDIO} = 1.89\text{V}$ | V_{DDIO} | | 55 | 150 | μA |
| I_{DDS2} | Supply Current Power Down | PDB = L, All LVCMOS inputs are floating or tied to GND | $V_{DD33} = 3.6\text{V}$ | V_{DD33} | | 1 | 2 | mA |
| | | | $V_{DDIO} = 3.6\text{V}$ | | | 65 | 150 | μA |
| I_{DDIOS2} | | | $V_{DDIO} = 1.89\text{V}$ | V_{DDIO} | | 50 | 150 | μA |

AC Electrical Characteristics

Over recommended operating supply and temperature ranges unless otherwise specified. (*Note 2, Note 3, Note 4*)

| Symbol | Parameter | Conditions | Pin/Freq. | Min | Typ | Max | Units | |
|------------------------------------|--|--|--|-----------|------------|-----------|-------|----|
| GPIO BIT RATE | | | | | | | | |
| B_R | Forward Channel Bit Rate | <i>(Note 8, Note 9)</i> | $f = 5 - 85$ MHz GPIO[3:0] | | $0.25 * f$ | | Mbps | |
| | Back Channel Bit Rate | | | | 75 | | kbps | |
| RECOMMENDED TIMING FOR PCLK | | | | | | | | |
| t_{TCP} | PCLK Period | <i>(Note 8, Note 9)</i> | PCLK | | 11.76 | T | 200 | ns |
| t_{CIH} | PCLK Input High Time | | | $0.4 * T$ | $0.5 * T$ | $0.6 * T$ | ns | |
| t_{CIL} | PCLK Input Low Time | | | $0.4 * T$ | $0.5 * T$ | $0.6 * T$ | ns | |
| t_{CLKT} | PCLK Input Transition Time <i>Figure 3 (Note 8, Note 9)</i> | | $f = 5$ MHz | 4.0 | | | ns | |
| | | | $f = 85$ MHz | 0.5 | | | ns | |
| t_{JIT} | PCLK Input Jitter Tolerance, Bit Error Rate $\leq 10^{-10}$ | $f / 40 < \text{Jitter Freq} < f / 20$ <i>(Note 10, Note 8)</i> | $f = 5 - 78\text{MHz}$ | 0.4 | 0.6 | | UI | |
| SWITCHING CHARACTERISTICS | | | | | | | | |
| t_{LHT} | CML Output Low-to-High Transition Time | See <i>Figure 1, Figure 4</i> | DOUT+, DOUT- | | 80 | 130 | ps | |
| t_{HLT} | CML Output High-to-Low Transition Time | | | 80 | 130 | ps | | |
| t_{DIS} | Data Input Setup to PCLK | See <i>Figure 5</i> | DIN[23:0], HS, VS, DE, PCLK, I2S_CLK, I2S_WC, I2S_DA, I2S_DB | 2.0 | | | ns | |
| t_{DIH} | Data Input Hold from PCLK | | | 2.0 | | | ns | |
| t_{PLD} | Serializer PLL Lock Time | <i>Figure 6 (Note 5)</i> | $f = 5 - 85$ MHz | | $131 * T$ | | ns | |
| t_{SD} | Delay — Latency | | $f = 5 - 85$ MHz | | $145 * T$ | | ns | |
| t_{TJIT} | Output Total Jitter, Bit Error Rate $\geq 10^{-10}$ <i>Figure 7 (Note 6, Note 8, Note 9)</i> | $R_L = 100\Omega$ $f = 85\text{MHz}$, LFMODE = L | DOUT+, DOUT- | | 0.25 | 0.30 | UI | |
| | | $R_L = 100\Omega$ $f = 5\text{MHz}$, LFMODE = H | | | 0.25 | 0.30 | UI | |

Recommended Timing for the Serial Control Bus

Over 3.3V supply and temperature ranges unless otherwise specified.

| Symbol | Parameter | Conditions | Min | Typ | Max | Units |
|---------------------|--|---------------|-----|-----|------|-------|
| f _{SCL} | SCL Clock Frequency | Standard Mode | 0 | | 100 | kHz |
| | | Fast Mode | 0 | | 400 | kHz |
| t _{LOW} | SCL Low Period | Standard Mode | 4.7 | | | us |
| | | Fast Mode | 1.3 | | | us |
| t _{HIGH} | SCL High Period | Standard Mode | 4.0 | | | us |
| | | Fast Mode | 0.6 | | | us |
| t _{HD;STA} | Hold time for a start or a repeated start condition <i>Figure 8</i> | Standard Mode | 4.0 | | | us |
| | | Fast Mode | 0.6 | | | us |
| t _{SU;STA} | Set Up time for a start or a repeated start condition <i>Figure 8</i> | Standard Mode | 4.7 | | | us |
| | | Fast Mode | 0.6 | | | us |
| t _{HD;DAT} | Data Hold Time <i>Figure 8</i> | Standard Mode | 0 | | 3.45 | us |
| | | Fast Mode | 0 | | 0.9 | us |
| t _{SU;DAT} | Data Set Up Time <i>Figure 8</i> | Standard Mode | 250 | | | ns |
| | | Fast Mode | 100 | | | ns |
| t _{SU;STO} | Set Up Time for STOP Condition, <i>Figure 8</i> | Standard Mode | 4.0 | | | us |
| | | Fast Mode | 0.6 | | | us |
| t _{BUF} | Bus Free Time Between STOP and START, <i>Figure 8</i> | Standard Mode | 4.7 | | | us |
| | | Fast Mode | 1.3 | | | us |
| t _r | SCL & SDA Rise Time, <i>Figure 8</i> | Standard Mode | | | 1000 | ns |
| | | Fast Mode | | | 300 | ns |
| t _f | SCL & SDA Fall Time, <i>Figure 8</i> | Standard Mode | | | 300 | ns |
| | | Fast mode | | | 300 | ns |

DC and AC Serial Control Bus Characteristics

Over 3.3V supply and temperature ranges unless otherwise specified. (*Note 2, Note 3, Note 4*)

| Symbol | Parameter | Conditions | Min | Typ | Max | Units |
|---------------------|-------------------------|--|---------------------------|-----|---------------------------|-------|
| V _{IH} | Input High Level | SDA and SCL | 0.7* V _{DD33} | | V _{DD33} | V |
| V _{IL} | Input Low Level Voltage | SDA and SCL | GND | | 0.3* V _{DD33} | V |
| V _{HY} | Input Hysteresis | | | >50 | | mV |
| V _{OL} | | SDA, IOL = 1.25mA | 0 | | 0.36 | V |
| I _{in} | | SDA or SCL, V _{in} = V _{DD33} or GND | -10 | | +10 | μA |
| t _R | SDA RiseTime – READ | SDA, RPU = 10kΩ, C _b ≤ 400pF, <i>Figure 8</i> | | 430 | | ns |
| t _F | SDA Fall Time – READ | | | 20 | | ns |
| t _{SU;DAT} | Set Up Time — READ | <i>Figure 8</i> | | 560 | | ns |
| t _{HD;DAT} | Hold Up Time — READ | <i>Figure 8</i> | | 615 | | ns |
| t _{SP} | Input Filter | | | 50 | | ns |
| C _{in} | Input Capacitance | SDA or SCL | | <5 | | pF |

Note 1: “Absolute Maximum Ratings” indicate limits beyond which damage to the device may occur, including inoperability and degradation of device reliability and/or performance. Functional operation of the device and/or non-degradation at the Absolute Maximum Ratings or other conditions beyond those indicated in the Recommended Operating Conditions is not implied. The Recommended Operating Conditions indicate conditions at which the device is functional and the device should not be operated beyond such conditions.

Note 2: The Electrical Characteristics tables list guaranteed specifications under the listed Recommended Operating Conditions except as otherwise modified or specified by the Electrical Characteristics Conditions and/or Notes. Typical specifications are estimations only and are not guaranteed.

Note 3: Typical values represent most likely parametric norms at $V_{DD} = 3.3V$, $T_a = +25 \text{ degC}$, and at the Recommended Operation Conditions at the time of product characterization and are not guaranteed.

Note 4: Current into device pins is defined as positive. Current out of a device pin is defined as negative. Voltages are referenced to ground except VOD and ΔVOD , which are differential voltages.

Note 5: t_{PLD} is the time required by the device to obtain lock when exiting power-down state with an active PCLK.

Note 6: UI – Unit Interval is equivalent to one serialized data bit width ($1UI = 1 / 35 \cdot PCLK$). The UI scales with PCLK frequency.

Note 7: Supply noise testing was done with minimum capacitors on the PCB. A sinusoidal signal is AC coupled to the V_{DD33} and V_{DDIO} supplies with amplitude = 100 mVp-p measured at the device V_{DD33} and V_{DDIO} pins. Bit error rate testing of input to the Ser and output of the Des with 10 meter cable shows no error when the noise frequency on the Ser is less than 50MHz. The Des on the other hand shows no error when the noise frequency is less than 50 MHz.

Note 8: Specification is guaranteed by characterization and is not tested in production.

Note 9: Specification is guaranteed by design and is not tested in production.

Note 10: Jitter Frequency is specified in conjunction with DS90UB926 PLL bandwidth.

AC Timing Diagrams and Test Circuits

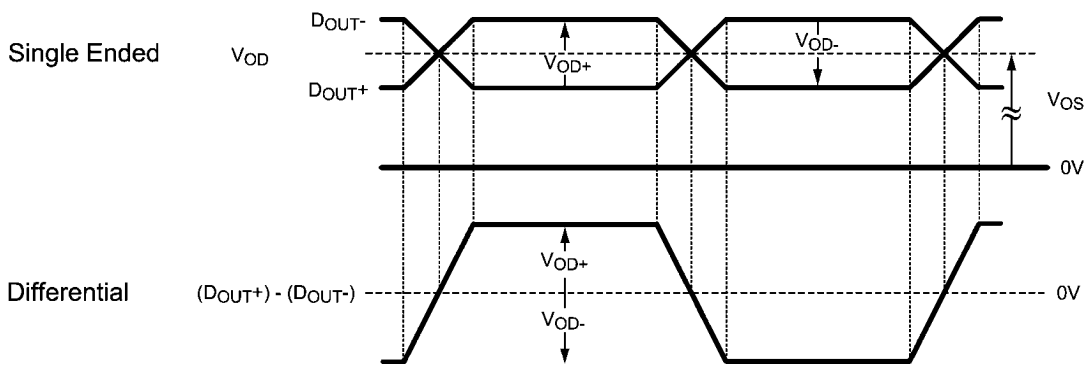
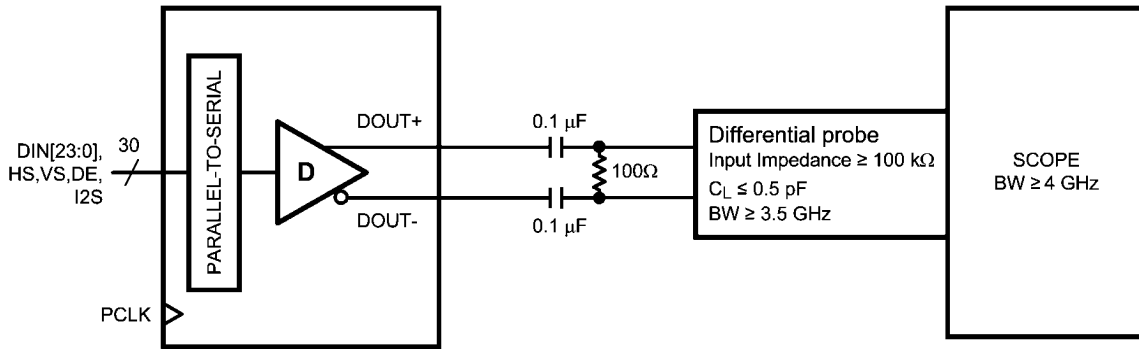

30143362

FIGURE 1. Serializer VOD DC Output

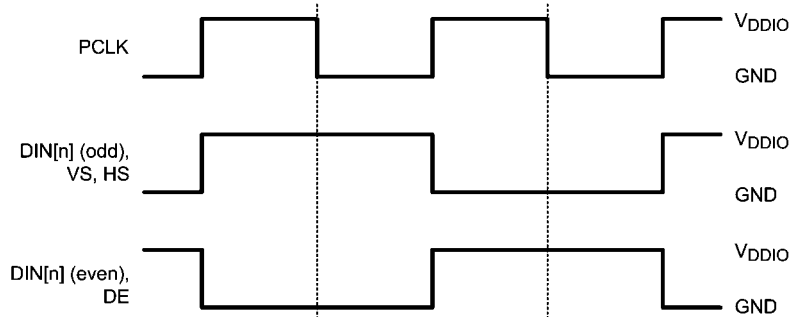

30143346

FIGURE 2. Checkboard Data Pattern

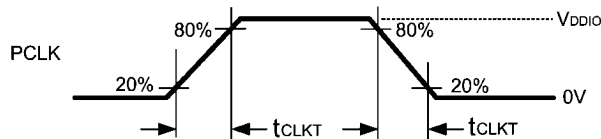

30143330

FIGURE 3. Serializer Input Clock Transition Time

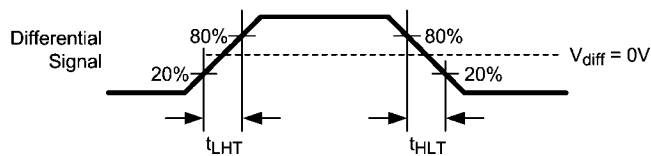

30143347

FIGURE 4. Serializer CML Output Load and Transition Time

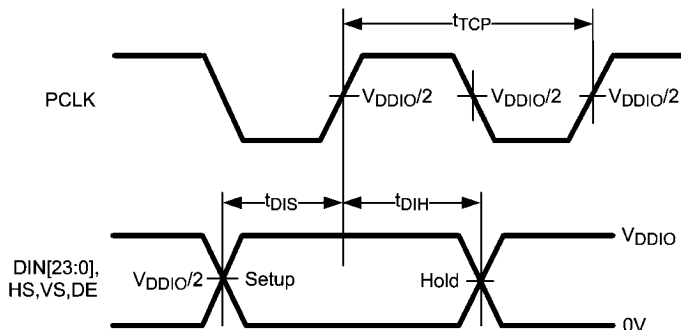

30143361

FIGURE 5. Serializer Setup and Hold Times

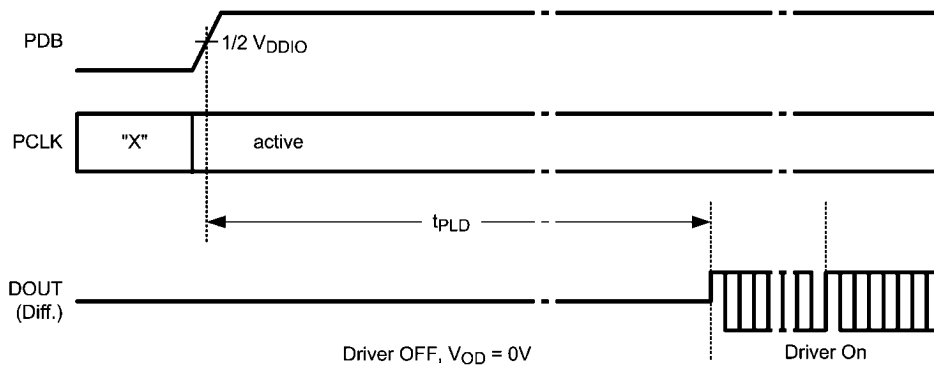

30143349

FIGURE 6. Serializer Lock Time

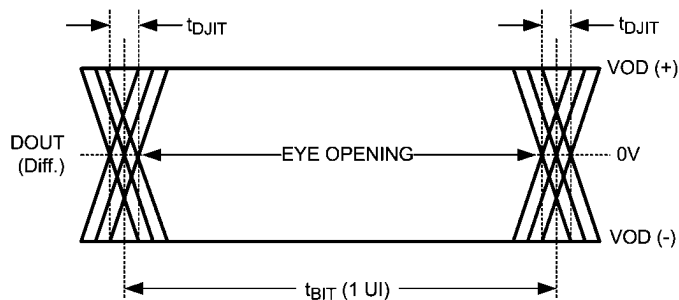

30143348

FIGURE 7. Serializer CML Output Jitter

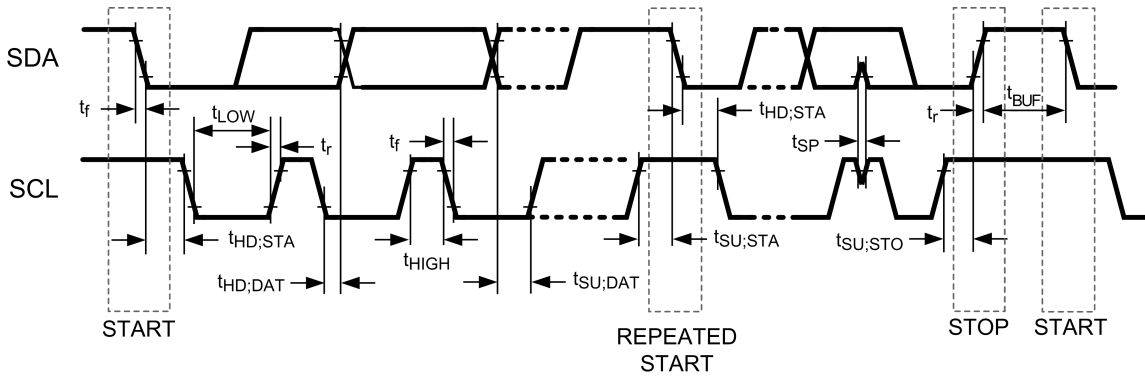

30143336

FIGURE 8. Serial Control Bus Timing Diagram

Functional Description

The DS90UB925Q serializer transmits a 35-bit symbol over a single serial FPD-Link III pair operating up to 2.975 Gbps line rate. The serial stream contains an embedded clock, video control signals and DC-balanced video data and audio data which enhance signal quality to support AC coupling. The serializer is intended for use with the DS90UB926Q deserializer, but is also backward compatible with DS90UR906Q or DS90UR908Q FPD-Link II deserializer.

The DS90UB925Q serializer and DS90UB926Q deserializer incorporate an I2C compatible interface. The I2C compatible interface allows programming of serializer or deserializer devices from a local host controller. In addition, the devices incorporate a bidirectional control channel (BCC) that allows communication between serializer/deserializer as well as remote I2C slave devices.

The bidirectional control channel is implemented via embedded signaling in the high-speed forward channel (serializer to deserializer) as well as lower speed signaling in the reverse channel (deserializer to serializer). Through this interface, the BCC provides a mechanism to bridge I2C transactions across the serial link from one I2C bus to another. The implementation allows for arbitration with other I2C compatible masters at either side of the serial link.

There are two operating modes available on DS90UB925Q, display mode and camera mode. In display mode, I2C transactions originate from the host controller attached to the serializer and target either the deserializer or an I2C slave attached to the deserializer. Transactions are detected by the I2C slave in the serializer and forwarded to the I2C master in the deserializer. Similarly, in camera mode, I2C transactions originate from a controller attached to the deserializer and target either the serializer or an I2C slave attached to the serializer. Transactions are detected by the I2C slave in the deserializer and forwarded to the I2C master in the serializer.

HIGH SPEED FORWARD CHANNEL DATA TRANSFER

The High Speed Forward Channel (HS_FC) is composed of 35 bits of data containing DIN[23:0] or RGB[7:0] or YUV data, sync signals, I2C, and I2S audio transmitted from Serializer to Deserializer. [Figure 9](#) illustrates the serial stream per PCLK cycle. This data payload is optimized for signal transmission over an AC coupled link. Data is randomized, balanced and scrambled.

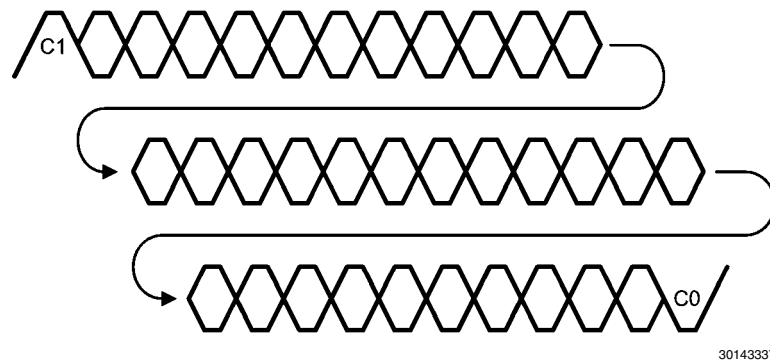

FIGURE 9. FPD-Link III Serial Stream

The device supports clocks in the range of 5 MHz to 85 MHz. The application payload rate is 2.975 Gbps maximum (175 Mbps minimum) with the actual line rate of 2.975 Gbps maximum and 525 Mbps Minimum.

LOW SPEED BACK CHANNEL DATA TRANSFER

The Low-Speed Backward Channel (LS_BC) of the DS90UB925Q provides bidirectional communication between the display and host processor. The information is carried back from the Deserializer to the Serializer per serial symbol. The back channel control data is transferred over the single serial link along with the high-speed forward data, DC balance coding and embedded clock information. This architecture provides a backward path across the serial link together with a high speed forward channel. The back channel contains the I2C, CRC and 4 bits of standard GPIO information with 10 Mbps line rate.

BACKWARD COMPATIBLE MODE

The DS90UB925Q is also backward compatible to DS90UR906Q and DS90UR908Q FPD Link II deserializers at 5-65 MHz of PCLK. It transmits 28-bits of data over a single serial FPD-Link II pair operating at the line rate of 140 Mbps to 1.82 Gbps. The backward configuration mode can be set via MODE_SEL pin ([Table 1](#)) or the configuration register ([Table 6](#)). Note: frequency range = 15 - 65MHz when LFMODE = 0 and frequency range = 5 - <15MHz when LFMODE = 1.

COMMON MODE FILTER PIN (CMF)

The serializer provides access to the center tap of the internal termination. A capacitor must be placed on this pin for additional common-mode filtering of the differential pair. This can be useful in high noise environments for additional noise rejection capability. A 0.1 μ F capacitor must be connected to this pin to Ground.

VIDEO CONTROL SIGNAL FILTER

When operating the devices in Normal Mode, the Video Control Signals (DE, HS, VS) have the following restrictions:

- Normal Mode with Control Signal Filter Enabled: DE and HS — Only 2 transitions per 130 clock cycles are transmitted, the transition pulse must be 3 PCLK or longer.
- Normal Mode with Control Signal Filter Disabled: DE and HS — Only 2 transitions per 130 clock cycles are transmitted, no restriction on minimum transition pulse.
- VS — Only 1 transition per 130 clock cycles are transmitted, minimum pulse width is 130 clock cycles.

Video Control Signals are defined as low frequency signals with limited transitions. Glitches of a control signal can cause a visual display error. This feature allows for the chipset to validate and filter out any high frequency noise on the control signals. See [Figure 10](#).

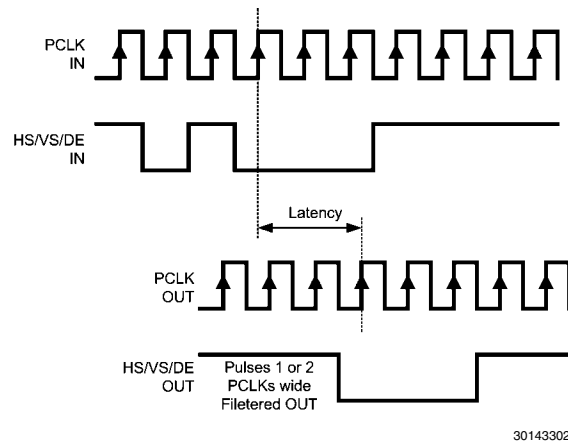

FIGURE 10. Video Control Signal Filter Waveform

EMI REDUCTION FEATURES

Input SSC Tolerance (SSCT)

The DS90UB925Q serializer is capable of tracking a triangular input spread spectrum clocking (SSC) profile up to $\pm 2.5\%$ amplitude deviations (center spread), up to 35 kHz modulation at 5–85 MHz, from a host source.

LVC MOS V_{DDIO} OPTION

1.8V or 3.3V Inputs and Outputs are powered from a separate V_{DDIO} supply to offer compatibility with external system interface signals. Note: When configuring the V_{DDIO} power supplies, all the single-ended data and control input pins for device need to scale together with the same operating V_{DDIO} levels.

POWER DOWN (PDB)

The Serializer has a PDB input pin to ENABLE or POWER DOWN the device. This pin can be controlled by the host or through the V_{DDIO} , where $V_{DDIO} = 3.0V$ to $3.6V$ or V_{DD33} . To save power disable the link when the display is not needed (PDB = LOW). When the pin is driven by the host, make sure to release it after V_{DD33} and V_{DDIO} have reached final levels; no external components are required. In the case of driven by the $V_{DDIO} = 3.0V$ to $3.6V$ or V_{DD33} directly, a 10 kohm resistor to the $V_{DDIO} = 3.0V$ to $3.6V$ or V_{DD33} , and a $>10\mu F$ capacitor to the ground are required (See [Figure 21](#) Typical Connection Diagram).

REMOTE AUTO POWER DOWN MODE

The Serializer features a remote auto power down mode. During the power down mode of the pairing deserializer, the Serializer enters the remote auto power down mode. In this mode, the power dissipation of the Serializer is reduced significantly. When the Deserializer is powered up, the Serializer enters the normal power on mode automatically. This feature is enabled through the register bit 0x01[7] [Table 6](#).

INPUT PCLK LOSS DETECT

The serializer can be programmed to enter a low power SLEEP state when the input clock (PCLK) is lost. A clock loss condition is detected when PCLK drops below approximately 1MHz. When a PCLK is detected again, the serializer will then lock to the incoming PCLK. Note – when PCLK is lost, the Serial Control Bus Registers values are still RETAINED.

SERIAL LINK FAULT DETECT

The serial link fault detection is able to detect any of following seven (7) conditions

- 1) cable open
- 2) “+” to “-“ short
- 3) “+” short to GND
- 4) “-“ short to GND
- 5) “+” short to battery
- 6) “-“ short to battery
- 7) Cable is linked correctly

If any one of the fault conditions occurs, The Link Detect Status is 0 (cable is not detected) on bit 0 of address 0x0C [Table 6](#).

PIXEL CLOCK EDGE SELECT (RFB)

The RFB control register bit selects which edge of the Pixel Clock is used. For the serializer, this pin determines the edge that the data is latched on. If RFB is HIGH ('1'), data is latched on the Rising edge of the PCLK. If RFB is LOW ('0'), data is latched on the Falling edge of the PCLK.

LOW FREQUENCY OPTIMIZATION (LFMODE)

The LFMODE is set via register (0x04[1:0]) or MODE_SEL Pin 24 ([Table 1](#)). It controls the operating frequency of the serializer. If LFMODE is Low (default), the PCLK frequency is between 15 MHz and 85 MHz. If LFMODE is High, the PCLK frequency is between 5 MHz and <15 MHz. Please note when the device LFMODE is changed, a PDB reset is required.

INTERRUPT PIN — FUNCTIONAL DESCRIPTION AND USAGE (INTB)

1. On DS90UB925, set register 0xC6[5] = 1 and 0xC6[0] = 1
2. DS90UB926Q deserializer INTB_IN (pin 16) is set LOW by some downstream device.
3. DS90UB925Q serializer pulls INTB (pin 31) LOW. The signal is active low, so a LOW indicates an interrupt condition.
4. External controller detects INTB = LOW; to determine interrupt source, read ISR register .
5. A read to ISR will clear the interrupt at the DS90UB925, releasing INTB.
6. The external controller typically must then access the remote device to determine downstream interrupt source and clear the interrupt driving INTB_IN. This would be when the downstream device releases the INTB_IN (pin 16) on the DS90UB926Q. The system is now ready to return to step (1) at next falling edge of INTB_IN.

CONFIGURATION SELECT (MODE_SEL)

Configuration of the device may be done via the MODE_SEL input pin, or via the configuration register bit. A pull-up resistor and a pull-down resistor of suggested values may be used to set the voltage ratio of the MODE_SEL input (V_{R4}) and V_{DD33} to select one of the other 10 possible selected modes. See [Figure 11](#) and [Table 1](#).

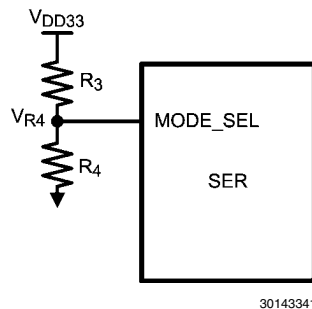

FIGURE 11. MODE_SEL Connection Diagram

TABLE 1. Configuration Select (MODE_SEL)

| # | Ideal Ratio V_{R4}/V_{DD33} | Ideal V_{R4} (V) | Suggested Resistor R3 k Ω (1% tol) | Suggested Resistor R4 k Ω (1% tol) | LFMODE | Repeater | Backward Compatible | I2S Channel B (18-bit Mode) |
|----|----------------------------------|-----------------------|---|---|--------|----------|------------------------|--------------------------------------|
| 1 | 0 | 0 | Open | 40.2 or Any | L | L | L | L |
| 2 | 0.121 | 0.399 | 294 | 40.2 | L | L | L | H |
| 3 | 0.152 | 0.502 | 280 | 49.9 | L | H | L | L |
| 4 | 0.242 | 0.799 | 240 | 76.8 | L | H | L | H |
| 5 | 0.311 | 1.026 | 226 | 102 | H | L | L | L |
| 6 | 0.402 | 1.327 | 196 | 130 | H | L | L | H |
| 7 | 0.492 | 1.624 | 169 | 165 | H | H | L | L |
| 8 | 0.583 | 1.924 | 137 | 191 | H | H | L | H |
| 9 | 0.629 | 2.076 | 124 | 210 | L | L | H | L |
| 10 | 0.727 | 2.399 | 90.9 | 243 | H | L | H | L |

LFMODE:

L = frequency range is 15 – 85 MHz (Default)

H = frequency range is 5 – <15 MHz

Repeater:

L = Repeater *OFF* (Default)

H = Repeater *ON*

Backward Compatible:

L = Backward Compatible is *OFF* (Default)

H = Backward Compatible is *ON*; DES = DS90UR906Q or DS90UR916Q or DS90UR908Q

– frequency range = 15 - 65MHz when LFMODE = 0

– frequency range = 5 - <15MHz when LFMODE = 1

I2S Channel B:

L = I2S Channel B is *OFF*, Normal 24-bit RGB Mode (Default)

H = I2S Channel B is *ON*, 18-bit RGB Mode with I2S_DB Enabled. Note: use of GPIO(s) on unused inputs must be enabled by register.

GPIO[3:0] and GPO_REG[8:4]

In 18-bit RGB operation mode, the optional R[1:0] and G[1:0] of the DS90UB925Q can be used as the general purpose IOs GPIO [3:0] in either forward channel (Inputs) or back channel (Outputs) application.

GPIO[3:0] Enable Sequence

See [Table 2](#) for the GPIO enable sequencing.

Step 1: Enable the 18-bit mode either through the configuration register bit [Table 6](#) on DS90UB925Q only. DS90UB926Q is automatically configured as in the 18-bit mode.

Step 2: To enable GPIO3 forward channel, write 0x03 to address 0x0F on DS90UB925Q, then write 0x05 to address 0x1F on DS90UB926Q.

TABLE 2. GPIO Enable Sequencing Table

| # | Description | Device | Forward Channel | Back Channel |
|---|--------------------|------------|---------------------------|---------------------------|
| 1 | Enable 18-bit mode | DS90UB925Q | 0x12 = 0x04 | 0x12 = 0x04 |
| | | DS90UB926Q | Auto Load from DS90UB925Q | Auto Load from DS90UB925Q |
| 2 | GPIO3 | DS90UB925Q | 0x0F = 0x03 | 0x0F = 0x05 |
| | | DS90UB926Q | 0x1F = 0x05 | 0x1F = 0x03 |
| 3 | GPIO2 | DS90UB925Q | 0x0E = 0x30 | 0x0E = 0x50 |
| | | DS90UB926Q | 0x1E = 0x50 | 0x1E = 0x30 |
| 4 | GPIO1 | DS90UB925Q | 0x0E = 0x03 | 0x0E = 0x05 |
| | | DS90UB926Q | 0x1E = 0x05 | 0x0E = 0x05 |
| 5 | GPIO0 | DS90UB925Q | 0x0D = 0x93 | 0x0D = 0x95 |
| | | DS90UB926Q | 0x1D = 0x95 | 0x1D = 0x93 |

GPO_REG[8:4] Enable Sequence

GPO_REG[8:4] are the outputs only pins. They must be programmed through the local register bits. See [Table 3](#) for the GPO_REG enable sequencing.

Step 1: Enable the 18-bit mode either through the configuration register bit on DS90UB925Q only. DS90UB926Q is automatically configured as in the 18-bit mode.

Step 2: To enable GPO_REG8 outputs an “1”, write 0x90 to address 0x11 on DS90UB925Q.

TABLE 3. GPO_REG Enable Sequencing Table

| # | Description | Device | Local Access | Local Output |
|---|--------------------|------------|--------------|--------------|
| 1 | Enable 18-bit mode | DS90UB925Q | 0x12 = 0x04 | |
| 2 | GPO_REG8 | DS90UB925Q | 0x11 = 0x90 | “1” |
| | | | 0x11 = 0x10 | “0” |
| 3 | GPO_REG7 | DS90UB925Q | 0x11 = 0x09 | “1” |
| | | | 0x11 = 0x01 | “0” |
| 4 | GPO_REG6 | DS90UB925Q | 0x10 = 0x90 | “1” |
| | | | 0x10 = 0x10 | “0” |
| 5 | GPO_REG5 | DS90UB925Q | 0x10 = 0x09 | “1” |
| | | | 0x10 = 0x01 | “0” |
| 6 | GPO_REG4 | DS90UB925Q | 0x0F = 0x90 | “1” |
| | | | 0x0F = 0x10 | “0” |

I2S TRANSMITTING

In normal 24-bit RGB operation mode, the DS90UB925Q supports 3 bits of I2S. They are I2S_CLK, I2S_WC and I2S_DA. The optionally packetized audio information can be transmitted during the video blanking (data island transport) or during active video (forward channel frame transport). Note: The bit rates of any I2S bits must maintain one fourth of the PCLK rate.

Secondary I2S Channel

In I2S Channel B operation mode, the secondary I2S data (I2S_DB) can be used as the additional I2S audio in addition to the 3-bit of I2S. The I2S_DB input must be synchronized to I2S_CLK and aligned with I2S_DA and I2S_WC at the input to the serializer. This operation mode is enabled through either the MODE_SEL pin ([Table 1](#)) or through the register bit 0x12[0] ([Table 6](#)).

[Table 4](#) below covers the range of I2S sample rates.

TABLE 4. Audio Interface Frequencies

| Sample Rate (kHz) | I2S Data Word Size (bits) | I2S CLK (MHz) |
|-------------------|---------------------------|---------------|
| 32 | 16 | 1.024 |
| 44.1 | 16 | 1.411 |
| 48 | 16 | 1.536 |
| 96 | 16 | 3.072 |
| 192 | 16 | 6.144 |
| 32 | 24 | 1.536 |
| 44.1 | 24 | 2.117 |
| 48 | 24 | 2.304 |
| 96 | 24 | 4.608 |
| 192 | 24 | 9.216 |
| 32 | 32 | 2.048 |
| 44.1 | 32 | 2.822 |
| 48 | 32 | 3.072 |
| 96 | 32 | 6.144 |
| 192 | 32 | 12.288 |

REPEATER APPLICATION

The DS90UB925Q and DS90UB926Q can be configured to extend data transmission over multiple links to multiple display devices. Setting the devices into repeater mode provides a mechanism for transmitting to all receivers in the system.

Repeater Configuration

In the repeater application, in this document, the DS90UB925Q is referred to as the Transmitter or transmit port (TX), and the DS90UB926Q is referred to as the Receiver (RX). [Figure 12](#) shows the maximum configuration supported for Repeater implementations using the DS90UB925Q (TX) and DS90UB926Q (RX). Two levels of Repeaters are supported with a maximum of three Transmitters per Receiver.

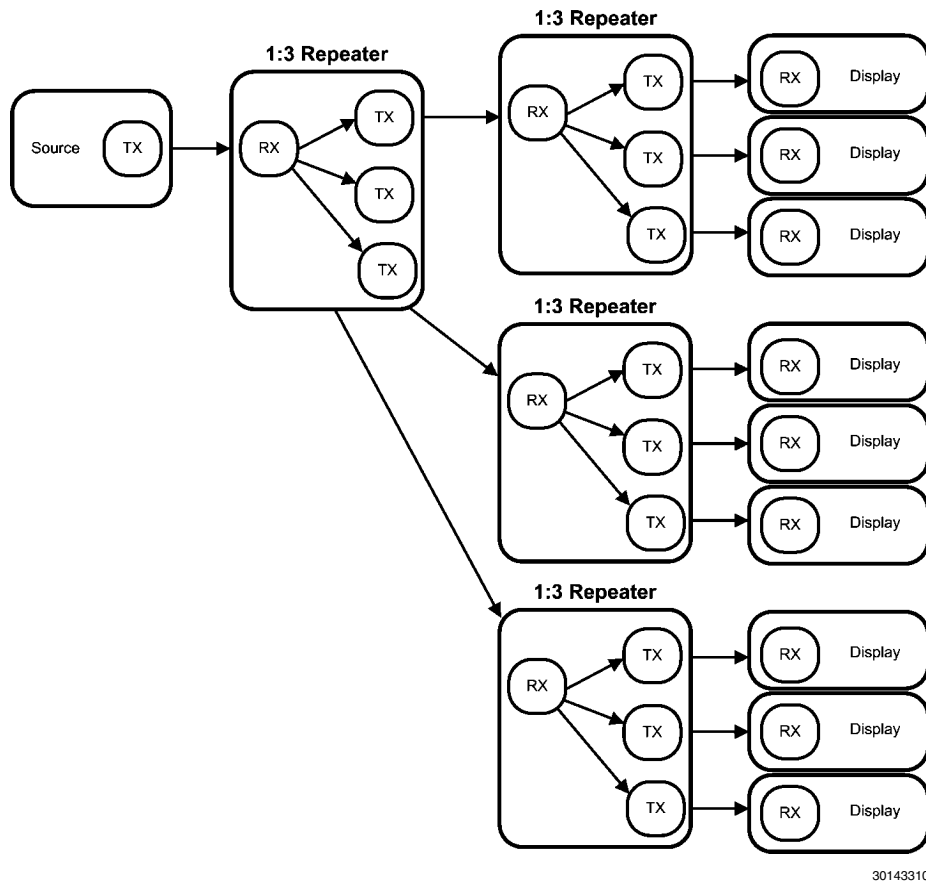
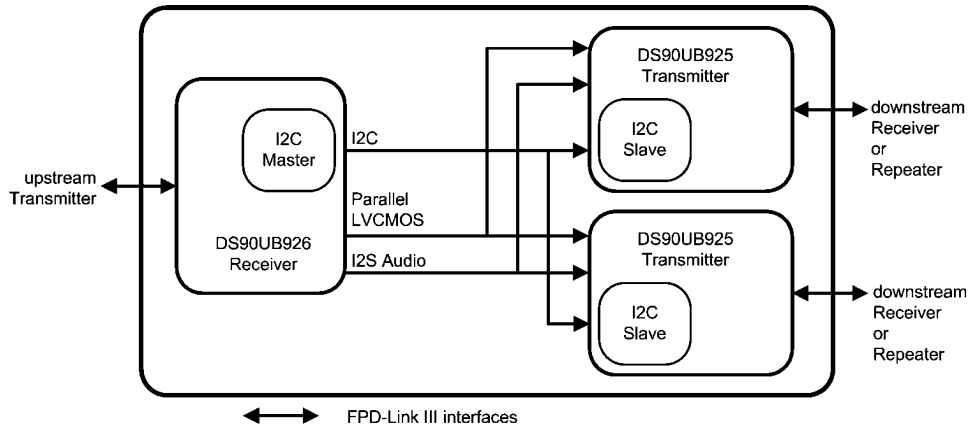

FIGURE 12. Maximum Repeater Application

In a repeater application, the I2C interface at each TX and RX may be configured to transparently pass I2C communications upstream or downstream to any I2C device within the system. This includes a mechanism for assigning alternate IDs (Slave Aliases) to downstream devices in the case of duplicate addresses.

At each repeater node, the parallel LVCMOS interface fans out to up to three serializer devices, providing parallel RGB video data, HS/VS/DE control signals and, optionally, packetized audio data (transported during video blanking intervals). Alternatively, the I2S audio interface may be used to transport digital audio data between receiver and transmitters in place of packetized audio. All audio and video data is transmitted at the output of the Receiver and is received by the Transmitter.

[Figure 13](#) provides more detailed block diagram of a 1:2 repeater configuration.



30143332

FIGURE 13. 1:2 Repeater Configuration

Repeater Connections

The Repeater requires the following connections between the Receiver and each Transmitter *Figure 14*.

- 1) Video Data – Connect PCLK, RGB and control signals (DE, VS, HS).
- 2) I2C – Connect SCL and SDA signals. Both signals should be pulled up to V_{DD33} with 4.7 k Ω resistors.
- 3) Audio – Connect I2S_CLK, I2S_WC, and I2S_DA signals.
- 4) IDx pin – Each Transmitter and Receiver must have an unique I2C address.
- 5) MODE_SEL pin – All Transmitter and Receiver must be set into the Repeater Mode.
- 6) Interrupt pin – Connect DS90UB926Q INTB_IN pin to DS90UB925Q INTB pin. The signal must be pulled up to V_{DDIO} .

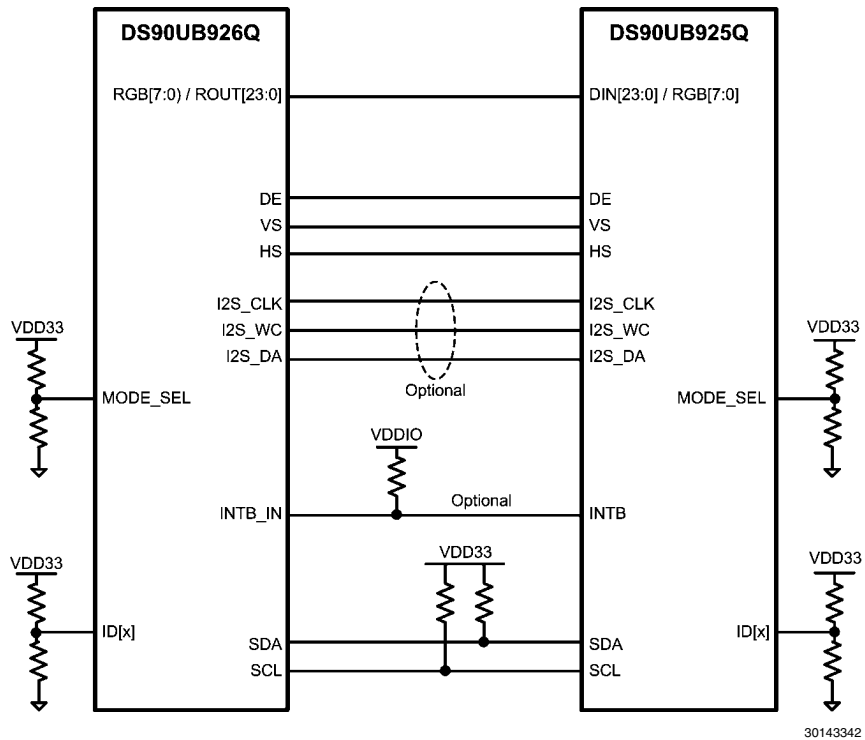

30143342

FIGURE 14. Repeater Connection Diagram

BUILT IN SELF TEST (BIST)

An optional At-Speed Built In Self Test (BIST) feature supports the testing of the high speed serial link and the low- speed back channel. This is useful in the prototype stage, equipment production, in-system test and also for system diagnostics. Note: BIST is not available in backwards compatible mode.

BIST Configuration and Status

The BIST mode is enabled at the deserializer by the Pin select (Pin 44 BISTEN and Pin 16 BISTC) or configuration register([Table 6](#)) through the deserializer. When LFMODE = 0, the pin based configuration defaults to external PCLK or 33 MHz internal Oscillator clock (OSC) frequency. In the absence of PCLK, the user can select the desired OSC frequency (default 33 MHz or 25MHz) through the register bit. When LFMODE = 1, the pin based configuration defaults to external PCLK or 12.5MHz internal Oscillator clock (OSC) frequency.

When BISTEN of the deserializer is high, the BIST mode enable information is sent to the serializer through the Back Channel. The serializer outputs a test pattern and drives the link at speed. The deserializer detects the test pattern and monitors it for errors. The PASS output pin toggles to flag any payloads that are received with 1 to 35 bit errors.

The BIST status is monitored real time on PASS pin. The result of the test is held on the PASS output until reset (new BIST test or Power Down). A high on PASS indicates NO ERRORS were detected. A Low on PASS indicates one or more errors were detected. The duration of the test is controlled by the pulse width applied to the deserializer BISTEN pin. This BIST feature also contains a Link Error Count and a Lock Status. If the connection of the serial link is broken, then the link error count is shown in the register. When the PLL of the deserializer is locked or unlocked, the lock status can be read in the register. See [Table 6](#).

Sample BIST Sequence

See [Figure 15](#) for the BIST mode flow diagram.

Step 1:For the DS90UB925Q and DS90UB926Q FPD-Link III chipset, BIST Mode is enabled via the BISTEN pin of DS90UB926Q FPD-Link III deserializer. The desired clock source is selected through BISTC pin.

Step 2:The DS90UB925Q serializer is woken up through the back channel if it is not already on. The all zero pattern on the data pins is sent through the FPD-Link III to the deserializer. Once the serializer and the deserializer are in BIST mode and the deserializer acquires Lock, the PASS pin of the deserializer goes high and BIST starts checking the data stream. If an error in the payload (1 to 35) is detected, the PASS pin will switch low for one half of the clock period. During the BIST test, the PASS output can be monitored and counted to determine the payload error rate.

Step 3:To Stop the BIST mode, the deserializer BISTEN pin is set Low. The deserializer stops checking the data. The final test result is held on the PASS pin. If the test ran error free, the PASS output will be High. If there was one or more errors detected, the PASS output will be Low. The PASS output state is held until a new BIST is run, the device is RESET, or Powered Down. The BIST duration is user controlled by the duration of the BISTEN signal.

Step 4:The Link returns to normal operation after the deserializer BISTEN pin is low. [Figure 16](#) shows the waveform diagram of a typical BIST test for two cases. Case 1 is error free, and Case 2 shows one with multiple errors. In most cases it is difficult to generate errors due to the robustness of the link (differential data transmission etc.), thus they may be introduced by greatly extending the cable length, faulting the interconnect, reducing signal condition enhancements (Rx Equalization).

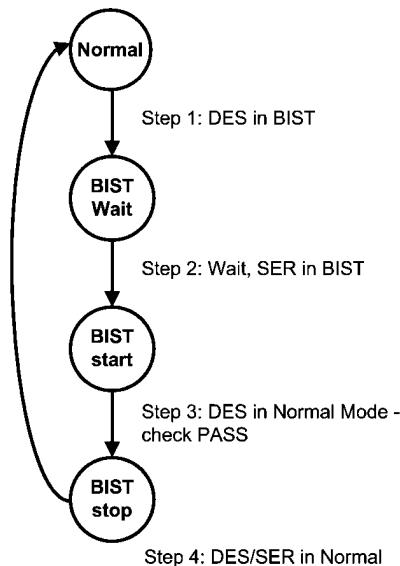

30143343

FIGURE 15. BIST Mode Flow Diagram

Forward Channel and Back Channel Error Checking

While in BIST mode, the serializer stops sampling RGB input pins and switches over to an internal all-zero pattern. The internal all-zeroes pattern goes through scrambler, dc-balancing etc. and goes over the serial link to the deserializer. The deserializer on locking to the serial stream compares the recovered serial stream with all-zeroes and records any errors in status registers and dynamically indicates the status on PASS pin. The deserializer then outputs a SSO pattern on the RGB output pins.

The back-channel data is checked for CRC errors once the serializer locks onto back-channel serial stream as indicated by link detect status (register bit 0x0C[0]). The CRC errors are recorded in an 8-bit register. The register is cleared when the serializer enters the BIST mode. As soon as the serializer exits BIST mode, the functional mode CRC register starts recording the CRC errors. The BIST mode CRC error register is active in BIST mode only and keeps the record of last BIST run until cleared or enters BIST mode again.

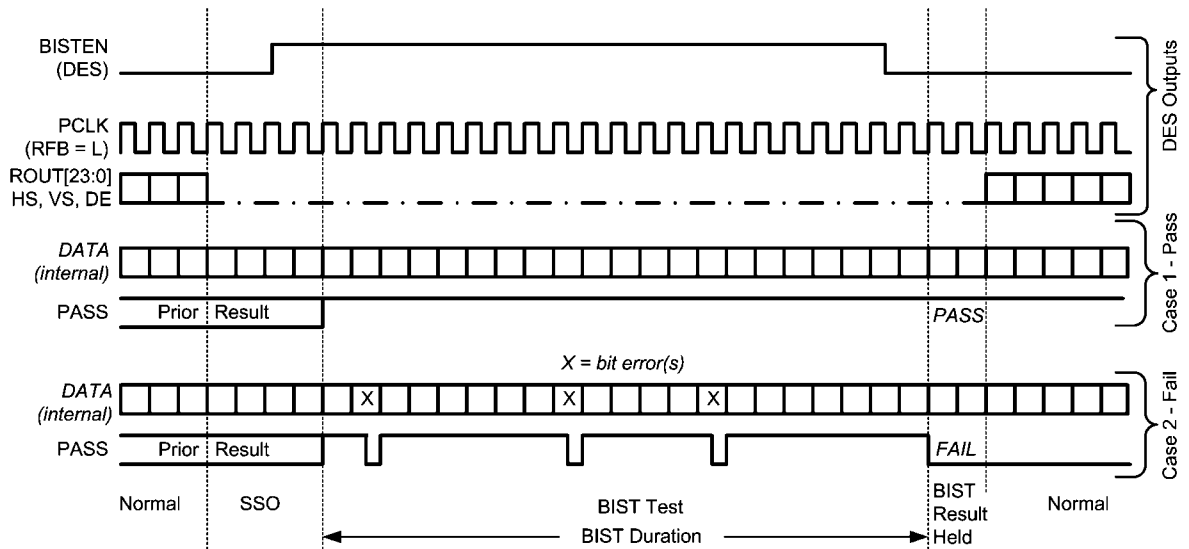

30143364

FIGURE 16. BIST Waveforms

Internal Pattern Generation

The DS90UB925Q serializer supports the internal pattern generation feature. It allows basic testing and debugging of an integrated panel through the FPD-Link III output stream. The test patterns are simple and repetitive and allow for a quick visual verification of panel operation. As long as the device is not in power down mode, the test pattern will be displayed even if no parallel input is applied. If no PCLK is received, the test pattern can be configured to use a programmed oscillator frequency. For detailed information, refer to Application Note AN-2198.

Serial Control Bus

The DS90UB925Q is configured by the use of a serial control bus that is I2C protocol compatible. Multiple serializer devices may share the serial control bus since 16 device addresses are supported. Device address is set via R_1 and R_2 values on IDx pin. See [Figure 17](#) below.

The serial control bus consists of two signals and a configuration pin. The SCL is a Serial Bus Clock Input / Output. The SDA is the Serial Bus Data Input / Output signal. Both SCL and SDA signals require an external pull-up resistor to V_{DD33} . For most applications a 4.7 k pull-up resistor to V_{DD33} may be used. The resistor value may be adjusted for capacitive loading and data rate requirements. The signals are either pulled High, or driven Low.

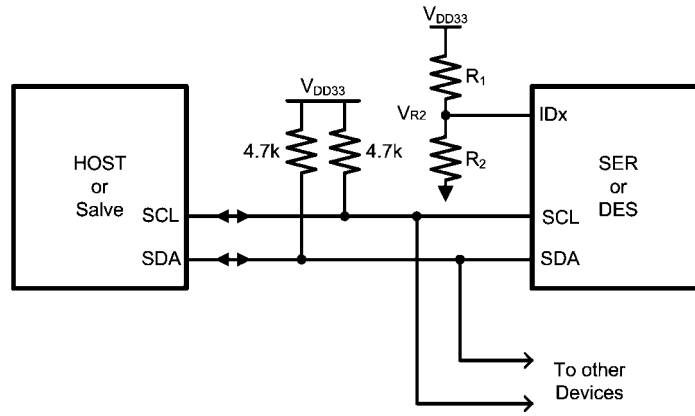

30143301

FIGURE 17. Serial Control Bus Connection

The configuration pin is the IDx pin. This pin sets one of 16 possible device addresses. A pull-up resistor and a pull-down resistor of suggested values may be used to set the voltage ratio of the IDx input (V_{R2}) and V_{DD33} to select one of the other 16 possible addresses. See [Table 6](#).

TABLE 5. Serial Control Bus Addresses for IDx

| # | Ideal Ratio V_{R2} / V_{DD33} | Ideal V_{R2} (V) | Suggested Resistor R1 kΩ (1% tol) | Suggested Resistor R2 kΩ (1% tol) | Address 7'b | Address 8'b Appended |
|----|------------------------------------|-----------------------|---|---|-------------|-------------------------|
| 1 | 0 | 0 | Open | 40.2 or Any | 0x0C | 0x18 |
| 2 | 0.121 | 0.399 | 294 | 40.2 | 0x0D | 0x1A |
| 3 | 0.152 | 0.502 | 280 | 49.9 | 0x0E | 0x1C |
| 4 | 0.182 | 0.601 | 270 | 60.4 | 0x0F | 0x1E |
| 5 | 0.212 | 0.700 | 267 | 71.5 | 0x10 | 0x20 |
| 6 | 0.242 | 0.799 | 240 | 76.8 | 0x11 | 0x22 |
| 7 | 0.273 | 0.901 | 243 | 90.9 | 0x12 | 0x24 |
| 8 | 0.310 | 1.023 | 226 | 102 | 0x13 | 0x26 |
| 9 | 0.356 | 1.175 | 210 | 115 | 0x14 | 0x28 |
| 10 | 0.402 | 1.327 | 196 | 130 | 0x15 | 0x2A |
| 11 | 0.447 | 1.475 | 182 | 147 | 0x16 | 0x2C |
| 12 | 0.492 | 1.624 | 169 | 165 | 0x17 | 0x2E |
| 13 | 0.538 | 1.775 | 154 | 180 | 0x18 | 0x30 |
| 14 | 0.583 | 1.924 | 137 | 191 | 0x19 | 0x32 |
| 15 | 0.629 | 2.076 | 124 | 210 | 0x1A | 0x34 |
| 16 | 0.727 | 2.399 | 90.9 | 243 | 0x1B | 0x36 |

The Serial Bus protocol is controlled by START, START-Repeated, and STOP phases. A START occurs when SCL transitions Low while SDA is High. A STOP occurs when SDA transition High while SCL is also HIGH. See [Figure 18](#).

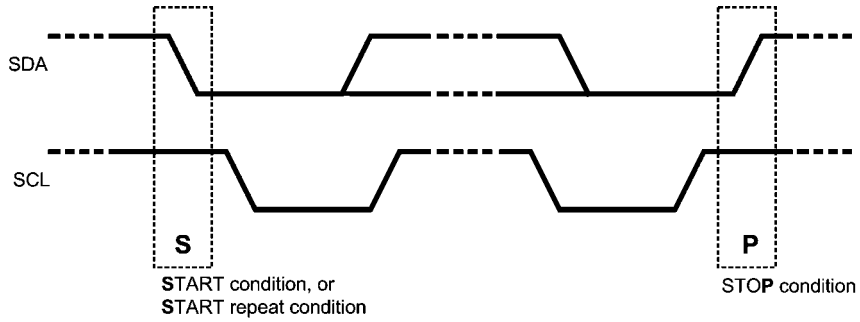

30143351

FIGURE 18. START and STOP Conditions

To communicate with a remote device, the host controller (master) sends the slave address and listens for a response from the slave. This response is referred to as an acknowledge bit (ACK). If a slave on the bus is addressed correctly, it Acknowledges (ACKs) the master by driving the SDA bus low. If the address doesn't match a device's slave address, it Not-acknowledges (NACKs) the master by letting SDA be pulled High. ACKs also occur on the bus when data is being transmitted. When the master is writing data, the slave ACKs after every data byte is successfully received. When the master is reading data, the master ACKs after every data byte is received to let the slave know it wants to receive another data byte. When the master wants to stop reading, it NACKs after the last data byte and creates a stop condition on the bus. All communication on the bus begins with either a Start condition or a Repeated Start condition. All communication on the bus ends with a Stop condition. A READ is shown in [Figure 19](#) and a WRITE is shown in [Figure 20](#).

If the Serial Bus is not required, the three pins may be left open (NC).

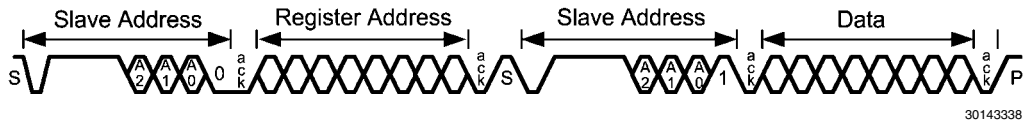

30143338

FIGURE 19. Serial Control Bus — READ

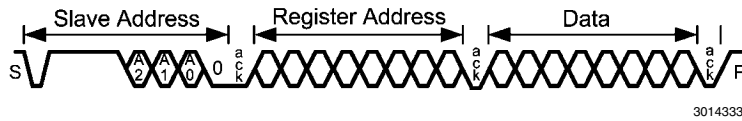

30143339

FIGURE 20. Serial Control Bus — WRITE

TABLE 6. Serial Control Bus Registers

| ADD (dec) | ADD (hex) | Register Name | Bit(s) | Register Type | Default (hex) | Function | Description |
|-----------|-----------|-------------------|--------|---------------|---------------|-----------------------------------|--|
| 0 | 0x00 | I2C Device ID | 7:1 | RW | | Device ID | 7-bit address of Serializer |
| | | | 0 | RW | | ID Setting | I2C ID Setting 1: Register I2C Device ID (Overrides IDx pin) 0: Device ID is from IDx pin |
| 1 | 0x01 | Reset | 7 | RW | 0x00 | Remote Auto Power Down | Remote Auto Power Down 1: Power down when no Bidirectional Control Channel link is detected 0: Do not power down when no Bidirectional Control Channel link is detected |
| | | | 6:2 | | | | Reserved |
| | | | 1 | RW | | Digital RESET1 | Reset the entire digital block including registers This bit is self-clearing. 1: Reset 0: Normal operation |
| | | | 0 | RW | | Digital RESET0 | Reset the entire digital block except registers This bit is self-clearing 1: Reset 0: Normal operation |
| 3 | 0x03 | Configuration [0] | 7 | RW | 0xD2 | Back channel CRC Checker Enable | Back Channel Check Enable 1: Enable 0: Disable |
| | | | 6 | | | | Reserved |
| | | | 5 | RW | | I2C Remote Write Auto Acknowledge | Automatically Acknowledge I2C Remote Write When enabled, I2C writes to the Deserializer (or any remote I2C Slave, if I2C PASS ALL is enabled) are immediately acknowledged without waiting for the Deserializer to acknowledge the write. This allows higher throughput on the I2C bus 1: Enable 0: Disable |
| | | | 4 | RW | | Filter Enable | HS, VS, DE two clock filter When enabled, pulses less than two full PCLK cycles on the DE, HS, and VS inputs will be rejected 1: Filtering enable 0: Filtering disable |
| | | | 3 | RW | | I2C Pass-through | I2C Pass-Through Mode 1: Pass-Through Enabled 0: Pass-Through Disabled |
| | | | 2 | | | | Reserved |
| | | | 1 | RW | | PCLK Auto | Switch over to internal OSC in the absence of PCLK 1: Enable auto-switch 0: Disable auto-switch |
| | | | 0 | RW | | TRFB | Pixel Clock Edge Select 1: Parallel Interface Data is strobed on the Rising Clock Edge. 0: Parallel Interface Data is strobed on the Falling Clock Edge. |

| ADD (dec) | ADD (hex) | Register Name | Bit(s) | Register Type | Default (hex) | Function | Description |
|-----------|-----------|-------------------|--------|---------------|---------------|---|--|
| 4 | 0x04 | Configuration [1] | 7 | RW | 0x80 | Failsafe State | Input Failsafe State 1: Failsafe to Low 0: Failsafe to High |
| | | | 6 | | | | Reserved |
| | | | 5 | RW | | CRC Error Reset | Clear back channel CRC Error Counters This bit is NOT self-clearing 1: Clear Counters 0: Normal Operation |
| | | | 4 | | | RGB DE Gate | 1: Gate RGB data with DE in Backward Compatibility mode and with Non-HDCP Deserializer 0: Pass RGB data independent of DE in Backward Compatibility mode and Non-HDCP operation (default) |
| | | | 3 | RW | | Backward Compatible select by pin or register control | Backward Compatible (BC) mode set by MODE_SEL pin or register 1: BC is set by register bit. Use register bit reg_0x04[2] to set BC Mode 0: BC is set by MODE_SEL pin. |
| | | | 2 | RW | | Backward Compatible Mode Select | Backward compatible (BC) mode to DS90UR906Q or DS90UR908Q, if reg_0x04[3] = 1 1: Backward compatible with DS90UR906Q or DS90UR908Q 0: Backward Compatible is OFF (default) |
| | | | 1 | RW | | LFMODE select by pin or register control | Frequency range is set by MODE_SEL pin or register 1: Frequency range is set by register. Use register bit reg_0x04[0] to set LFMODE 0: Frequency range is set by MODE_SEL pin. |
| | | | 0 | RW | | LFMODE | Frequency range select 1: PCLK range = 5MHz - <15 MHz), if reg_0x04[1] = 1 0: PCLK range = 15MHz - 85MHz (default) |

| ADD (dec) | ADD (hex) | Register Name | Bit(s) | Register Type | Default (hex) | Function | Description |
|-----------|-----------|---------------|--------|---------------|---------------|-----------------------|--|
| 5 | 0x05 | I2C Control | 7:5 | | 0x00 | | Reserved |
| | | | 4:3 | RW | | SDA Output Delay | SDA output delay Configures output delay on the SDA output. Setting this value will increase output delay in units of 40ns. Nominal output delay values for SCL to SDA are 00: 240ns 01: 280ns 10: 320ns 11: 360ns |
| | | | 2 | RW | | Local Write Disable | Disable remote writes to local registers Setting the bit to a 1 prevents remote writes to local device registers from across the control channel. It prevents writes to the Serializer registers from an I2C master attached to the Deserializer. Setting this bit does not affect remote access to I2C slaves at the Serializer |
| | | | 1 | RW | | I2C Bus Timer Speedup | Speed up I2C bus watchdog timer 1: Watchdog timer expires after ~50 ms. 0: Watchdog Timer expires after ~1 s |
| | | | 0 | RW | | I2C Bus timer Disable | Disable I2C bus watchdog timer When the I2C watchdog timer may be used to detect when the I2C bus is free or hung up following an invalid termination of a transaction. If SDA is high and no signalling occurs for ~1 s, the I2C bus assumes to be free. If SDA is low and no signaling occurs, the device attempts to clear the bus by driving 9 clocks on SCL |
| 6 | 0x06 | DES ID | 7:1 | RW | 0x00 | DES Device ID | 7-bit Deserializer Device ID Configures the I2C Slave ID of the remote Deserializer. A value of 0 in this field disables I2C access to the remote Deserializer. This field is automatically configured by the Bidirectional Control Channel once RX Lock has been detected. Software may overwrite this value, but should also assert the FREEZE DEVICE ID bit to prevent overwriting by the Bidirectional Control Channel. |
| | | | 0 | RW | | Device ID Frozen | Freeze Deserializer Device ID Prevents autoloading of the Deserializer Device ID by the Bidirectional Control Channel. The ID will be frozen at the value written. |
| 7 | 0x07 | Slave ID | 7:1 | RW | 0x00 | Slave Device ID | 7-bit Remote Slave Device ID Configures the physical I2C address of the remote I2C Slave device attached to the remote Deserializer. If an I2C transaction is addressed to the Slave Device Alias ID, the transaction will be remapped to this address before passing the transaction across the Bidirectional Control Channel to the Deserializer |
| | | | 0 | | | | Reserved |

| ADD (dec) | ADD (hex) | Register Name | Bit(s) | Register Type | Default (hex) | Function | Description |
|-----------|-----------|------------------------------------|--------|---------------|---------------|-----------------------|---|
| 8 | 0x08 | Slave Alias | 7:1 | RW | 0x00 | Slave Device Alias ID | 7-bit Remote Slave Device Alias ID Assigns an Alias ID to an I2C Slave device attached to the remote Deserializer. The transaction will be remapped to the address specified in the Slave ID register. A value of 0 in this field disables access to the remote I2C Slave. |
| | | | 0 | | | | Reserved |
| 10 | 0x0A | CRC Errors | 7:0 | R | 0x00 | CRC Error LSB | Number of back channel CRC errors – 8 least significant bits |
| 11 | 0x0B | | 7:0 | R | 0x00 | CRC Error MSB | Number of back channel CRC errors – 8 most significant bits |
| 12 | 0x0C | General Status | 7:4 | | 0x00 | | Reserved |
| | | | 3 | R | | BIST CRC Error | Back channel CRC error during BIST communication with Deserializer. The bit is cleared upon loss of link, restart of BIST, or assertion of CRC ERROR RESET in register 0x04. |
| | | | 2 | R | | PCLK Detect | PCLK Status 1: Valid PCLK detected 0: Valid PCLK not detected |
| | | | 1 | R | | DES Error | Back channel CRC error during communication with Deserializer. The bit is cleared upon loss of link or assertion of CRC ERROR RESET in register 0x04. |
| | | | 0 | R | | LINK Detect | LINK Status 1: Cable link detected 0: Cable link not detected (Fault Condition) |
| 13 | 0x0D | Revision ID and GPIO Configuration | 7:4 | R | 0xA0 | Rev-ID | Revision ID: 1010 Production Device |
| | | | 3 | RW | | GPIO0 Output Value | Local GPIO output value This value is output on the GPIO pin when the GPIO function is enabled, the local GPIO direction is Output, and remote GPIO control is disabled. |
| | | | 2 | RW | | GPIO0 Remote Enable | Remote GPIO control 1: Enable GPIO control from remote Deserializer. The GPIO pin will be an output, and the value is received from the remote Deserializer. 0: Disable GPIO control from remote Deserializer. |
| | | | 1 | RW | | GPIO0 Direction | Local GPIO Direction 1: Input 0: Output |
| | | | 0 | RW | | GPIO0 Enable | GPIO function enable 1: Enable GPIO operation 0: Enable normal operation |

| ADD (dec) | ADD (hex) | Register Name | Bit(s) | Register Type | Default (hex) | Function | Description |
|-----------|-----------|-----------------------------------|--------|---------------|---------------|-----------------------|--|
| 14 | 0x0E | GPIO2 and GPIO1 Configurations | 7 | RW | 0x00 | GPIO2 Output Value | Local GPIO output value This value is output on the GPIO pin when the GPIO function is enabled, the local GPIO direction is Output, and remote GPIO control is disabled. |
| | | | 6 | RW | | GPIO2 Remote Enable | Remote GPIO control 1: Enable GPIO control from remote Deserializer. The GPIO pin will be an output, and the value is received from the remote Deserializer. 0: Disable GPIO control from remote Deserializer. |
| | | | 5 | RW | | GPIO2 Direction | Local GPIO Direction 1: Input 0: Output |
| | | | 4 | RW | | GPIO2 Enable | GPIO function enable 1: Enable GPIO operation 0: Enable normal operation |
| | | | 3 | RW | | GPIO1 Output Value | Local GPIO output value This value is output on the GPIO pin when the GPIO function is enabled, the local GPIO direction is Output, and remote GPIO control is disabled. |
| | | | 2 | RW | | GPIO1 Remote Enable | Remote GPIO control 1: Enable GPIO control from remote Deserializer. The GPIO pin will be an output, and the value is received from the remote Deserializer. 0: Disable GPIO control from remote Deserializer. |
| | | | 1 | RW | | GPIO1 Direction | Local GPIO Direction 1: Input 0: Output |
| | | | 0 | RW | | GPIO1 Enable | GPIO function enable 1: Enable GPIO operation 0: Enable normal operation |
| 15 | 0x0F | GPO_REG4 and GPIO3 Configurations | 7 | RW | 0x00 | GPO_REG4 Output Value | Local GPO_REG4 output value This value is output on the GPO pin when the GPO function is enabled. (The local GPO direction is Output, and remote GPO control is disabled) |
| | | | 6:5 | | | | Reserved |
| | | | 4 | RW | | GPO_REG4 Enable | GPO_REG4 function enable 1: Enable GPO operation 0: Enable normal operation |
| | | | 3 | RW | | GPIO3 Output Value | Local GPIO output value This value is output on the GPIO pin when the GPIO function is enabled, the local GPIO direction is Output, and remote GPIO control is disabled. |
| | | | 2 | RW | | GPIO3 Remote Enable | Remote GPIO control 1: Enable GPIO control from remote Deserializer. The GPIO pin will be an output, and the value is received from the remote Deserializer. 0: Disable GPIO control from remote Deserializer. |
| | | | 1 | RW | | GPIO3 Direction | Local GPIO Direction 1: Input 0: Output |
| | | | 0 | RW | | GPIO3 Enable | GPIO function enable 1: Enable GPIO operation 0: Enable normal operation |

| ADD (dec) | ADD (hex) | Register Name | Bit(s) | Register Type | Default (hex) | Function | Description |
|-----------|-----------|--------------------------------------|--------|---------------|---------------|-----------------------|---|
| 16 | 0x10 | GPO_REG6 and GPO_REG5 Configurations | 7 | RW | 0x00 | GPO_REG6 Output Value | Local GPO_REG6 output value This value is output on the GPO pin when the GPO function is enabled. (The local GPO direction is Output, and remote GPO control is disabled) |
| | | | 6:5 | | | | Reserved |
| | | | 4 | RW | | GPO_REG6 Enable | GPO_REG6 function enable 1: Enable GPO operation 0: Enable normal operation |
| | | | 3 | RW | | GPO_REG5 Output Value | Local GPO_REG5 output value This value is output on the GPO pin when the GPO function is enabled, the local GPO direction is Output, and remote GPO control is disabled. |
| | | | 2:1 | | | | Reserved |
| | | | 0 | RW | | GPO_REG5 Enable | GPO_REG5 function enable 1: Enable GPO operation 0: Enable normal operation |
| 17 | 0x11 | GPO_REG8 and GPO_REG7 Configurations | 7 | RW | 0x00 | GPO_REG8 Output Value | Local GPO_REG8 output value This value is output on the GPO pin when the GPO function is enabled. (The local GPO direction is Output, and remote GPO control is disabled) |
| | | | 6:5 | | | | Reserved |
| | | | 4 | RW | | GPO_REG8 Enable | GPO_REG8 function enable 1: Enable GPO operation 0: Enable normal operation |
| | | | 3 | RW | | GPO_REG7 Output Value | Local GPO_REG7 output value This value is output on the GPO pin when the GPO function is enabled, the local GPO direction is Output, and remote GPO control is disabled. |
| | | | 2:1 | | | | Reserved |
| | | | 0 | RW | | GPO_REG7 Enable | GPO_REG7 function enable 1: Enable GPO operation 0: Enable normal operation |

| ADD (dec) | ADD (hex) | Register Name | Bit(s) | Register Type | Default (hex) | Function | Description |
|-----------|-----------|---|--------|---------------|---|--|--|
| 18 | 0x12 | Data Path Control | 7:6 | | 0x00 | | Reserved |
| | | | 5 | RW | | DE Polarity | The bit indicates the polarity of the DE (Data Enable) signal. 1: DE is inverted (active low, idle high) 0: DE is positive (active high, idle low) |
| | | | 4 | RW | | I2S Repeater Regen | I2S Repeater Regeneration 1: Repeater regenerate I2S from I2S pins 0: Repeater pass through I2S from video pins |
| | | | 3 | RW | | I2S Channel B Enable Override | I2S Channel B Enable 1: Set I2S Channel B Enable from reg_12[0] 0: Set I2S Channel B Enable from MODE_SEL pin |
| | | | 2 | RW | | 18-bit Video Select | 18-bit video select 1: Select 18-bit video mode Note: use of GPIO(s) on unused inputs must be enabled by register. 0: Select 24-bit video mode |
| | | | 1 | RW | | I2S Transport Select | I2S Transport Mode Slect 1: Enable I2S Data Forward Channel Frame Transport 0: Enable I2S Data Island Transport |
| | | | 0 | RW | | I2S Channel B Enable | I2S Channel B Enable 1: Enable I2S Channel B on B1 input 0: I2S Channel B disabled |
| | | | 19 | 0x13 | | Mode Status | 7:5 |
| 4 | R | MODE_SEL | | | MODE_SEL Status 1: MODE_SEL decode circuit is completed 0: MODE_SEL decode circuit is not completed | | |
| 3 | R | Low Frequency Mode | | | Low Frequency Mode Status 1: Low frequency (5 - <15 MHz) 0: Normal frequency (15 - 85 MHz) | | |
| 2 | R | Repeater Mode | | | Repeater Mode Status 1: Repeater mode <i>ON</i> 0: Repeater Mode <i>OFF</i> | | |
| 1 | R | Backward Compatible Mode | | | Backward Compatible Mode Status 1: Backward compatible <i>ON</i> 0: Backward compatible <i>OFF</i> | | |
| 0 | R | I2S Channel B Mode | | | I2S Channel B Mode Status 1: I2S Channel B <i>ON</i> , 18-bit RGB mode with I2S_DB enabled 0: I2S Channel B <i>OFF</i> ; normal 24-bit RGB mode | | |
| 20 | 0x14 | Oscillator Clock Source and BIST Status | | | 7:3 | | |
| | | | 2:1 | RW | OSC Clock Source | OSC Clock Source (When LFMODE = 1, Oscillator = 12.5MHz ONLY) 00: External Pixel Clock 01: 33 MHz Oscillator 10: Reserved 11: 25 MHz Oscillator | |
| | | | 0 | R | BIST Enable Status | BIST status 1: Enabled 0: Disabled | |

| ADD (dec) | ADD (hex) | Register Name | Bit(s) | Register Type | Default (hex) | Function | Description |
|-----------|-----------|----------------------|--------|---------------|---------------|-------------------------------------|--|
| 22 | 0x16 | BCC Watchdog Control | 7:1 | RW | 0xFE | Timer Value | The watchdog timer allows termination of a control channel transaction if it fails to complete within a programmed amount of time. This field sets the Bidirectional Control Channel Watchdog Timeout value in units of 2 ms. This field should not be set to 0 |
| | | | 0 | RW | | Timer Control | Disable Bidirectional Control Channel Watchdog Timer 1: Disables BCC Watchdog Timer operation 0: Enables BCC Watchdog Timer operation |
| 23 | 0x17 | I2C Control | 7 | RW | 0x5E | I2C Pass All | I2C Control 1: Enable Forward Control Channel pass-through of all I2C accesses to I2C Slave IDs that do not match the Serializer I2C Slave ID. 0: Enable Forward Control Channel pass-through only of I2C accesses to I2C Slave IDs matching either the remote Deserializer Slave ID or the remote Slave ID. |
| | | | 6 | | | | Reserved |
| | | | 5:4 | RW | | SDA Hold Time | Internal SDA Hold Time Configures the amount of internal hold time provided for the SDA input relative to the SCL input. Units are 40 ns |
| | | | 3:0 | RW | | I2C Filter Depth | Configures the maximum width of glitch pulses on the SCL and SDA inputs that will be rejected. Units are 5 ns |
| 24 | 0x18 | SCL High Time | 7:0 | RW | 0xA1 | SCL HIGH Time | I2C Master SCL High Time This field configures the high pulse width of the SCL output when the Serializer is the Master on the local I2C bus. Units are 40 ns for the nominal oscillator clock frequency. The default value is set to provide a minimum 5us SCL high time with the internal oscillator clock running at 32.5MHz rather than the nominal 25MHz. |
| 25 | 0x19 | SCL Low Time | 7:0 | RW | 0xA5 | SCL LOW Time | I2C SCL Low Time This field configures the low pulse width of the SCL output when the Serializer is the Master on the local I2C bus. This value is also used as the SDA setup time by the I2C Slave for providing data prior to releasing SCL during accesses over the Bidirectional Control Channel. Units are 40 ns for the nominal oscillator clock frequency. The default value is set to provide a minimum 5us SCL low time with the internal oscillator clock running at 32.5MHz rather than the nominal 25MHz. |
| 27 | 0x1B | BIST BC Error | 7:0 | R | 0x00 | BIST Back Channel CRC Error Counter | BIST Mode Back Channel CRC Error Counter This error counter is active only in the BIST mode. It clears itself at the start of the BIST run. |

| ADD (dec) | ADD (hex) | Register Name | Bit(s) | Register Type | Default (hex) | Function | Description |
|-----------|-----------|---------------------------|--------|---------------|---------------|--------------------------|--|
| 100 | 0x64 | Pattern Generator Control | 7:4 | RW | 0x10 | Pattern Generator Select | <p>Fixed Pattern Select</p> <p>This field selects the pattern to output when in Fixed Pattern Mode. Scaled patterns are evenly distributed across the horizontal or vertical active regions. This field is ignored when Auto-Scrolling Mode is enabled. The following table shows the color selections in non-inverted followed by inverted color mode</p> <p>0000: Reserved</p> <p>0001: White/Black</p> <p>0010: Black/White</p> <p>0011: Red/Cyan</p> <p>0100: Green/Magenta</p> <p>0101: Blue/Yellow</p> <p>0110: Horizontally Scaled Black to White/White to Black</p> <p>0111: Horizontally Scaled Black to Red/Cyan to White</p> <p>1000: Horizontally Scaled Black to Green/Magenta to White</p> <p>1001: Horizontally Scaled Black to Blue/Yellow to White</p> <p>1010: Vertically Scaled Black to White/White to Black</p> <p>1011: Vertically Scaled Black to Red/Cyan to White</p> <p>1100: Vertically Scaled Black to Green/Magenta to White</p> <p>1101: Vertically Scaled Black to Blue/Yellow to White</p> <p>1110: Custom color (or its inversion) configured in PGRS, PGGS, PGBS registers</p> <p>1111: Reserved</p> |
| | | | 3:1 | | | | Reserved |
| | | | 0 | RW | | Pattern Generator Enable | <p>1: Enable Pattern Generator</p> <p>0: Disable Pattern Generator</p> |

| ADD (dec) | ADD (hex) | Register Name | Bit(s) | Register Type | Default (hex) | Function | Description |
|-----------|-----------|------------------------------------|--------|---------------|---------------|--------------------------------------|--|
| 101 | 0x65 | Pattern Generator Configuration | 7:5 | | 0x00 | | Reserved |
| | | | 4 | RW | | Pattern Generator 18 Bits | 18-bit Mode Select 1: Enable 18-bit color pattern generation. Scaled patterns will have 64 levels of brightness and the R, G, and B outputs use the six most significant color bits. 0: Enable 24-bit pattern generation. Scaled patterns use 256 levels of brightness. |
| | | | 3 | RW | | Pattern Generator External Clock | Select External Clock Source 1: Selects the external pixel clock when using internal timing. 0: Selects the internal divided clock when using internal timing This bit has no effect in external timing mode (PATGEN_TSEL = 0). |
| | | | 2 | RW | | Pattern Generator Timing Select | Timing Select Control 1: The Pattern Generator creates its own video timing as configured in the Pattern Generator Total Frame Size, Active Frame Size, Horizontal Sync Width, Vertical Sync Width, Horizontal Back Porch, Vertical Back Porch, and Sync Configuration registers. 0: the Pattern Generator uses external video timing from the pixel clock, Data Enable, Horizontal Sync, and Vertical Sync signals. |
| | | | 1 | RW | | Pattern Generator Color Invert | Enable Inverted Color Patterns 1: Invert the color output. 0: Do not invert the color output. |
| | | | 0 | RW | | Pattern Generator Auto-Scroll Enable | Auto-Scroll Enable: 1: The Pattern Generator will automatically move to the next enabled pattern after the number of frames specified in the Pattern Generator Frame Time (PGFT) register. 0: The Pattern Generator retains the current pattern. |
| 102 | 0x66 | Pattern Generator Indirect Address | 7:0 | RW | 0x00 | Indirect Address | This 8-bit field sets the indirect address for accesses to indirectly-mapped registers. It should be written prior to reading or writing the Pattern Generator Indirect Data register. See AN-2198 |
| 103 | 0x67 | Pattern Generator Indirect Data | 7:0 | RW | 0x00 | Indirect Data | When writing to indirect registers, this register contains the data to be written. When reading from indirect registers, this register contains the read back value. See AN-2198 |
| 198 | 0xC6 | ICR | 7:6 | | | | Reserved |
| | | | 5 | RW | | IS_RX_INT | Interrupt on Receiver interrupt Enables interrupt on indication from the Receiver. Allows propagation of interrupts from downstream devices |
| | | | 4:1 | | | | Reserved |
| | | | 0 | RW | | INT Enable | Global Interrupt Enable Enables interrupt on the interrupt signal to the controller. |

| ADD (dec) | ADD (hex) | Register Name | Bit(s) | Register Type | Default (hex) | Function | Description |
|-----------|-----------|---------------|--------|---------------|---------------|-----------|--|
| 199 | 0xC7 | ISR | 7:6 | | | | Reserved |
| | | | 5 | R | | IS RX INT | Interrupt on Receiver interrupt Receiver has indicated an interrupt request from down-stream device |
| | | | 4:1 | | | | Reserved |
| | | | 0 | R | | INT | Global Interrupt Set if any enabled interrupt is indicated |
| 240 | 0xF0 | TX ID | 7:0 | R | 0x5F | ID0 | First byte ID code, '_' |
| 241 | 0xF1 | | 7:0 | R | 0x55 | ID1 | Second byte of ID code, 'U' |
| 242 | 0xF2 | | 7:0 | R | 0x48 | ID2 | Third byte of ID code. Value will be 'B' |
| 243 | 0xF3 | | 7:0 | R | 0x39 | ID3 | Forth byte of ID code: '9' |
| 244 | 0xF4 | | 7:0 | R | 0x32 | ID4 | Fifth byte of ID code: "2" |
| 245 | 0xF5 | | 7:0 | R | 0x35 | ID5 | Sixth byte of ID code: "5" |

Applications Information

DISPLAY APPLICATION

The DS90UB925Q, in conjunction with the DS90UB926Q, is intended for interface between a host (graphics processor) and a Display. It supports a 24-bit color depth (RGB888) and high definition (720p) digital video format. It can receive a three 8-bit RGB stream with a pixel rate up to 85 MHz together with three control bits (VS, HS and DE) and three I2S-bus audio stream with an audio sampling rate up to 192 kHz.

TYPICAL APPLICATION CONNECTION

Figure 21 shows a typical application of the DS90UB925Q serializer for an 85 MHz 24-bit Color Display Application. The CML outputs must have an external 0.1 μ F AC coupling capacitor on the high speed serial lines. The serializer has an internal termination. Bypass capacitors are placed near the power supply pins. At a minimum, six (6) 4.7 μ F capacitors should be used for local device bypassing. Ferrite beads are placed on the two (2) VDDs (V_{DD33} and V_{DDIO}) for effective noise suppression. The interface to the graphics source is with 3.3V LVCMOS levels, thus the V_{DDIO} pin is connected to the 3.3 V rail. A RC delay is placed on the PDB signal to delay the enabling of the device until power is stable.

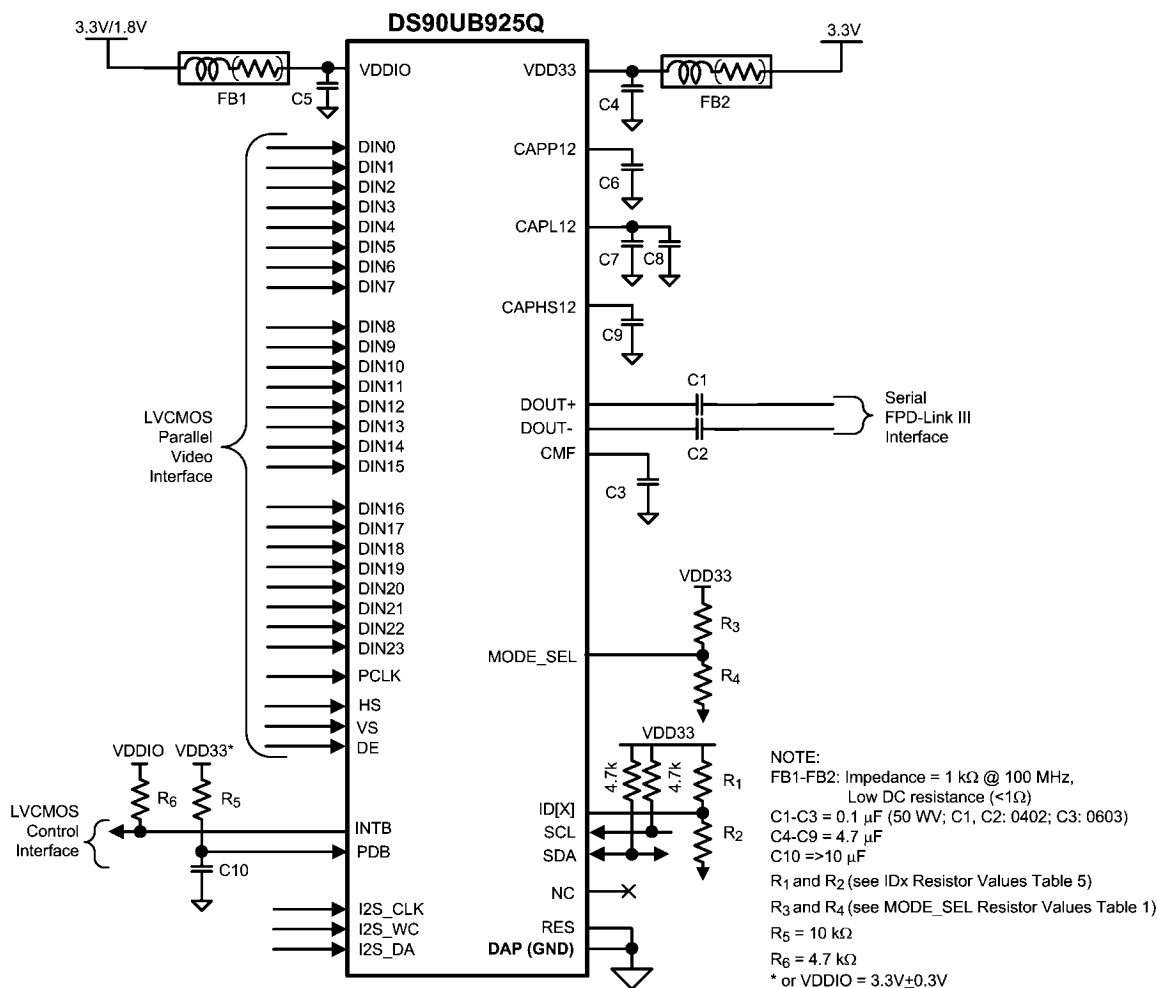

FIGURE 21. Typical Connection Diagram

30143344

POWER UP REQUIREMENTS AND PDB PIN

The VDDs (V_{DD33} and V_{DDIO}) supply ramp should be faster than 1.5 ms with a monotonic rise. A large capacitor on the PDB pin is needed to ensure PDB arrives after all the VDDs have settled to the recommended operating voltage. When PDB pin is pulled to $V_{DDIO} = 3.0V$ to $3.6V$ or V_{DD33} , it is recommended to use a 10 k Ω pull-up and a >10 uF cap to GND to delay the PDB input signal. All inputs must not be driven until V_{DD33} and V_{DDIO} has reached its steady state value.

PCB LAYOUT AND POWER SYSTEM CONSIDERATIONS

Circuit board layout and stack-up for the FPD-Link III devices should be designed to provide low-noise power feed to the device. Good layout practice will also separate high frequency or high-level inputs and outputs to minimize unwanted stray noise pickup, feedback and interference. Power system performance may be greatly improved by using thin dielectrics (2 to 4 mils) for power / ground sandwiches. This arrangement provides plane capacitance for the PCB power system with low-inductance parasitics, which has proven especially effective at high frequencies, and makes the value and placement of external bypass capacitors less critical. External bypass capacitors should include both RF ceramic and tantalum electrolytic types. RF capacitors may use values in the range of 0.01 uF to 0.1 uF. Tantalum capacitors may be in the 2.2 uF to 10 uF range. Voltage rating of the tantalum capacitors should be at least 5X the power supply voltage being used.

Surface mount capacitors are recommended due to their smaller parasitics. When using multiple capacitors per supply pin, locate the smaller value closer to the pin. A large bulk capacitor is recommended at the point of power entry. This is typically in the 50uF to 100uF range and will smooth low frequency switching noise. It is recommended to connect power and ground pins directly to the power and ground planes with bypass capacitors connected to the plane with via on both ends of the capacitor. Connecting power or ground pins to an external bypass capacitor will increase the inductance of the path.

A small body size X7R chip capacitor, such as 0603 or 0402, is recommended for external bypass. Its small body size reduces the parasitic inductance of the capacitor. The user must pay attention to the resonance frequency of these external bypass capacitors, usually in the range of 20-30 MHz. To provide effective bypassing, multiple capacitors are often used to achieve low impedance between the supply rails over the frequency of interest. At high frequency, it is also a common practice to use two vias from power and ground pins to the planes, reducing the impedance at high frequency.

Some devices provide separate power and ground pins for different portions of the circuit. This is done to isolate switching noise effects between different sections of the circuit. Separate planes on the PCB are typically not required. Pin Description tables typically provide guidance on which circuit blocks are connected to which power pin pairs. In some cases, an external filter may be used to provide clean power to sensitive circuits such as PLLs.

Use at least a four layer board with a power and ground plane. Locate LVCMOS signals away from the CML lines to prevent coupling from the LVCMOS lines to the CML lines. Closely-coupled differential lines of 100 Ohms are typically recommended for CML interconnect. The closely coupled lines help to ensure that coupled noise will appear as common-mode and thus is rejected by the receivers. The tightly coupled lines will also radiate less.

Information on the LLP style package is provided in TI Application Note: AN-1187.

CML INTERCONNECT GUIDELINES

See AN-1108 and AN-905 for full details.

- Use 100 Ω coupled differential pairs
- Use the S/2S/3S rule in spacings
 - S = space between the pair
 - 2S = space between pairs
 - 3S = space to LVCMOS signal
- Minimize the number of Vias
- Use differential connectors when operating above 500 Mbps line speed
- Maintain balance of the traces
- Minimize skew within the pair

Additional general guidance can be found in the LVDS Owner's Manual - available in PDF format from the Texas Instruments web site at: www.ti.com/lvds

Revision

- **March 30, 2012**
 - Web release
- **July 19, 2012**
 - Converted to hybrid TI format
 - Corrected typo in “Pin Descriptions” SCL from pin 6 to pin 8
 - Corrected typo in “Pin Descriptions” SDA from pin 7 to pin 9
 - Corrected typo in “TABLE 1. Configuration Select (MODE_SEL)” #6 “I2S Channel B (18-bit Mode)” from L to H
 - Corrected typo in TABLE 5. Serial Control Bus Addresses for IDx #11 Ideal $V_{R2}(V)$ from 2.475 to 1.475
 - Added “Note: BIST is not available in backwards compatible mode.”
 - Corrected typo in table “DC and AC Serial Control Bus Characteristics” from VDDIO to VDD33
- **Aug 7, 2012**
 - Added” Note: frequency range = 15 - 65MHz when LFMODE = 0 and frequency range = 5 - <15MHz when LFMODE = 1.” under Functional Description. Reformatted TABLE 1 and added clarification to notes. Added clarification to notes on TABLE 6 Serial Control Bus Registers, address 0x04[3:0] (backwards compatible and LFMODE registers).

Physical Dimensions inches (millimeters) unless otherwise noted

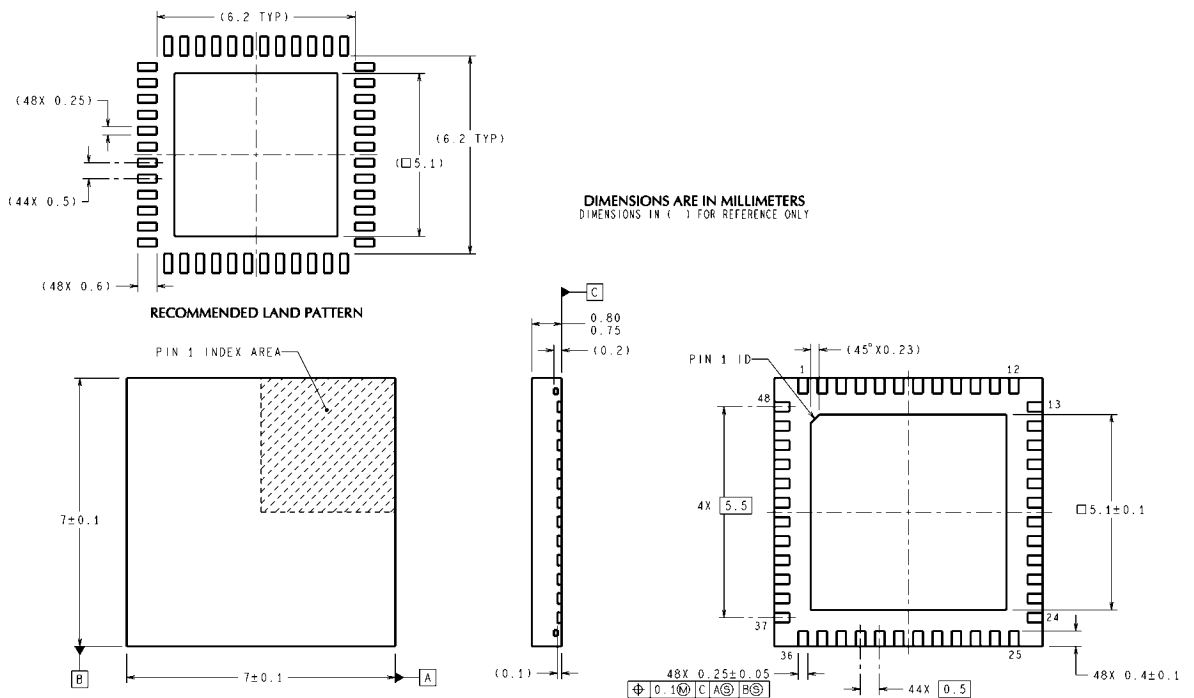

**48-pin LLP Package (7.0 mm X 7.0 mm X 0.8 mm, 0.5 mm pitch)
NS Package Number SQA48A**

Notes

IMPORTANT NOTICE

Texas Instruments Incorporated and its subsidiaries (TI) reserve the right to make corrections, enhancements, improvements and other changes to its semiconductor products and services per JESD46, latest issue, and to discontinue any product or service per JESD48, latest issue. Buyers should obtain the latest relevant information before placing orders and should verify that such information is current and complete. All semiconductor products (also referred to herein as "components") are sold subject to TI's terms and conditions of sale supplied at the time of order acknowledgment.

TI warrants performance of its components to the specifications applicable at the time of sale, in accordance with the warranty in TI's terms and conditions of sale of semiconductor products. Testing and other quality control techniques are used to the extent TI deems necessary to support this warranty. Except where mandated by applicable law, testing of all parameters of each component is not necessarily performed.

TI assumes no liability for applications assistance or the design of Buyers' products. Buyers are responsible for their products and applications using TI components. To minimize the risks associated with Buyers' products and applications, Buyers should provide adequate design and operating safeguards.

TI does not warrant or represent that any license, either express or implied, is granted under any patent right, copyright, mask work right, or other intellectual property right relating to any combination, machine, or process in which TI components or services are used. Information published by TI regarding third-party products or services does not constitute a license to use such products or services or a warranty or endorsement thereof. Use of such information may require a license from a third party under the patents or other intellectual property of the third party, or a license from TI under the patents or other intellectual property of TI.

Reproduction of significant portions of TI information in TI data books or data sheets is permissible only if reproduction is without alteration and is accompanied by all associated warranties, conditions, limitations, and notices. TI is not responsible or liable for such altered documentation. Information of third parties may be subject to additional restrictions.

Resale of TI components or services with statements different from or beyond the parameters stated by TI for that component or service voids all express and any implied warranties for the associated TI component or service and is an unfair and deceptive business practice. TI is not responsible or liable for any such statements.

Buyer acknowledges and agrees that it is solely responsible for compliance with all legal, regulatory and safety-related requirements concerning its products, and any use of TI components in its applications, notwithstanding any applications-related information or support that may be provided by TI. Buyer represents and agrees that it has all the necessary expertise to create and implement safeguards which anticipate dangerous consequences of failures, monitor failures and their consequences, lessen the likelihood of failures that might cause harm and take appropriate remedial actions. Buyer will fully indemnify TI and its representatives against any damages arising out of the use of any TI components in safety-critical applications.

In some cases, TI components may be promoted specifically to facilitate safety-related applications. With such components, TI's goal is to help enable customers to design and create their own end-product solutions that meet applicable functional safety standards and requirements. Nonetheless, such components are subject to these terms.

No TI components are authorized for use in FDA Class III (or similar life-critical medical equipment) unless authorized officers of the parties have executed a special agreement specifically governing such use.

Only those TI components which TI has specifically designated as military grade or "enhanced plastic" are designed and intended for use in military/aerospace applications or environments. Buyer acknowledges and agrees that any military or aerospace use of TI components which have **not** been so designated is solely at the Buyer's risk, and that Buyer is solely responsible for compliance with all legal and regulatory requirements in connection with such use.

TI has specifically designated certain components which meet ISO/TS16949 requirements, mainly for automotive use. Components which have not been so designated are neither designed nor intended for automotive use; and TI will not be responsible for any failure of such components to meet such requirements.

Products

| | |
|------------------------------|--|
| Audio | www.ti.com/audio |
| Amplifiers | amplifier.ti.com |
| Data Converters | dataconverter.ti.com |
| DLP® Products | www.dlp.com |
| DSP | dsp.ti.com |
| Clocks and Timers | www.ti.com/clocks |
| Interface | interface.ti.com |
| Logic | logic.ti.com |
| Power Mgmt | power.ti.com |
| Microcontrollers | microcontroller.ti.com |
| RFID | www.ti-rfid.com |
| OMAP Applications Processors | www.ti.com/omap |
| Wireless Connectivity | www.ti.com/wirelessconnectivity |

Applications

| | |
|-------------------------------|--|
| Automotive and Transportation | www.ti.com/automotive |
| Communications and Telecom | www.ti.com/communications |
| Computers and Peripherals | www.ti.com/computers |
| Consumer Electronics | www.ti.com/consumer-apps |
| Energy and Lighting | www.ti.com/energy |
| Industrial | www.ti.com/industrial |
| Medical | www.ti.com/medical |
| Security | www.ti.com/security |
| Space, Avionics and Defense | www.ti.com/space-avionics-defense |
| Video and Imaging | www.ti.com/video |

TI E2E Community

e2e.ti.com